

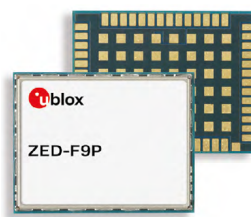

ZED-F9P

u-blox F9 high precision GNSS module

Integration manual



Abstract

This document describes the features and application of the ZED-F9P, a multi-band GNSS module with integrated RTK offering centimeter level accuracy.

www.u-blox.com

UBX-18010802 - R08



Document information

Title	ZED-F9P		
Subtitle	u-blox F9 high precision GNSS module		
Document type	Integration manual		
Document number	UBX-18010802		
Revision and date	R08		02-Jun-2020
Document status	Early production information		

This document applies to the following products:

Product name	Type number	Firmware version	PCN reference
ZED-F9P	ZED-F9P-02B-00	HPG 1.13	

u-blox reserves all rights to this document and the information contained herein. Products, names, logos and designs described herein may in whole or in part be subject to intellectual property rights. Reproduction, use, modification or disclosure to third parties of this document or any part thereof without the express permission of u-blox is strictly prohibited.

The information contained herein is provided "as is" and u-blox assumes no liability for the use of the information. No warranty, either express or implied, is given with respect to, including but not limited to, the accuracy, correctness, reliability and fitness for a particular purpose of the information. This document may be revised by u-blox at any time. For most recent documents, please visit www.u-blox.com.

Copyright © 2020, u-blox AG.

u-blox is a registered trademark of u-blox Holding AG in the EU and other countries.

Contents

1 Integration manual structure.....	6
2 System description.....	7
2.1 Overview.....	7
2.1.1 Real time kinematic.....	7
2.2 Architecture.....	8
2.2.1 Block diagram.....	8
2.2.2 Typical ZED-F9P application setups.....	8
3 Receiver functionality.....	11
3.1 Receiver configuration.....	11
3.1.1 Changing the receiver configuration.....	11
3.1.2 Default GNSS configuration.....	11
3.1.3 Default interface settings.....	12
3.1.4 Basic receiver configuration.....	12
3.1.5 RTK configuration.....	15
3.1.6 Legacy configuration interface compatibility.....	22
3.1.7 Navigation configuration.....	22
3.2 SBAS.....	27
3.3 QZSS SLAS.....	28
3.3.1 Features.....	29
3.3.2 Configuration.....	29
3.4 Geofencing.....	30
3.4.1 Introduction.....	30
3.4.2 Interface.....	30
3.4.3 Geofence state evaluation.....	30
3.4.4 Using a PIO for geofence state output.....	31
3.5 Logging.....	31
3.5.1 Introduction.....	31
3.5.2 Setting the logging system up.....	31
3.5.3 Information about the log.....	32
3.5.4 Recording.....	32
3.5.5 Retrieval.....	34
3.5.6 Command message acknowledgment.....	34
3.6 Communication interfaces.....	35
3.6.1 UART interfaces.....	36
3.6.2 I2C interface.....	37
3.6.3 SPI interface.....	40
3.6.4 USB interface.....	41
3.7 Predefined PIOs.....	42
3.7.1 D_SEL.....	42
3.7.2 RESET_N.....	42
3.7.3 SAFEBOOT_N.....	42
3.7.4 TIMEPULSE.....	42
3.7.5 TX_READY.....	43
3.7.6 EXTINT.....	43

3.7.7	GEOFENCE_STAT interface.....	43
3.7.8	RTK_STAT interface.....	44
3.8	Antenna supervisor.....	44
3.8.1	Antenna voltage control - ANT_OFF.....	45
3.8.2	Antenna short detection - ANT_SHORT_N.....	46
3.8.3	Antenna short detection auto recovery.....	46
3.8.4	Antenna open circuit detection - ANT_DETECT.....	47
3.9	Multiple GNSS assistance (MGA).....	47
3.9.1	Authorization.....	48
3.9.2	Multiple servers.....	48
3.9.3	Preserving information during power-off.....	48
3.9.4	AssistNow Online.....	48
3.10	Clocks and time.....	52
3.10.1	Receiver local time.....	52
3.10.2	Navigation epochs.....	52
3.10.3	iTOW timestamps.....	53
3.10.4	GNSS times.....	53
3.10.5	Time validity.....	54
3.10.6	UTC representation.....	54
3.10.7	Leap seconds.....	55
3.10.8	Real time clock.....	55
3.10.9	Date.....	55
3.11	Timing functionality.....	56
3.11.1	Time pulse.....	56
3.11.2	Timemark.....	60
3.12	Security.....	61
3.12.1	Spoofing detection / monitoring.....	61
3.12.2	Jamming/interference indicator.....	62
3.12.3	GNSS receiver integrity.....	63
3.13	u-blox protocol feature descriptions.....	63
3.13.1	Broadcast navigation data.....	63
3.14	Forcing a receiver reset.....	70
3.15	Spectrum analyzer.....	70
4	Design.....	71
4.1	Pin assignment.....	71
4.2	Power supply.....	73
4.2.1	VCC: Main supply voltage.....	73
4.2.2	V_BCKP: Backup supply voltage.....	73
4.2.3	ZED-F9P power supply.....	74
4.3	ZED-F9P minimal design.....	74
4.4	Antenna.....	75
4.4.1	Antenna bias.....	77
4.5	EOS/ESD precautions.....	79
4.5.1	ESD protection measures.....	79
4.5.2	EOS precautions.....	80
4.5.3	Safety precautions.....	80
4.6	Electromagnetic interference on I/O lines.....	80
4.6.1	General notes on interference issues.....	81
4.6.2	In-band interference mitigation.....	81
4.6.3	Out-of-band interference.....	82

4.7 Layout.....	82
4.7.1 Placement.....	82
4.7.2 Package footprint, copper and paste mask.....	82
4.7.3 Layout guidance.....	84
4.8 Design guidance.....	86
4.8.1 General considerations.....	86
4.8.2 Backup battery.....	86
4.8.3 RF front-end circuit options.....	86
4.8.4 Antenna/RF input.....	87
4.8.5 Ground pads.....	88
4.8.6 Schematic design.....	88
4.8.7 Layout design-in guideline.....	88
5 Product handling.....	89
5.1 ESD handling precautions.....	89
5.2 Soldering.....	89
5.3 Tapes.....	92
5.4 Reels.....	93
5.5 Moisture sensitivity levels.....	93
Appendix.....	94
A Glossary.....	94
B RTCM ITRF geodetic models.....	94
C RTK configuration procedures with u-center.....	96
C.1 Base configuration with u-center.....	96
C.2 Rover configuration with u-center.....	100
D Stacked patch antenna.....	104
Related documents.....	108
Revision history.....	109

1 Integration manual structure

This document provides a wealth of information to enable a successful design with the ZED-F9P module. The manual is structured according to system, software and hardware aspects.

The first section, "System description" outlines the basics of enabling RTK operation with the ZED-F9P. This is essential reading for anyone new to the device to enable them to understand a working RTK implementation.

The following section "Receiver functionality" provides an exhaustive description of the receiver's functionality. Beginning with the new configuration messages, both existing and new users should read this section to understand the new message types employed. Most of the following subsections should be familiar to existing users of u-blox positioning products, however some changes are introduced owing to the new configuration messages.

The sections from "Design" onwards address hardware options when designing the ZED-F9P into a new product. This part gives power supply recommendations and provides guidance for circuit design and PCB lay-out assistance. The "Antenna" section provides design information and recommendation for this important component. A final "Design guidance" section helps the designer to check that crucial aspects of the design-in process have been carried out.

The final section addresses the general product handling concerns giving guidance on ESD precautions, production soldering considerations and module delivery tape and reel information.

2 System description

2.1 Overview

The ZED-F9P positioning module features the new u-blox F9 receiver platform, which provides multi-band GNSS to high volume industrial applications in a compact form factor. The module with integrated RTK enables precise navigation and automation of moving machinery in industrial and consumer grade products in a small surface mounted form factor of only 17.0 x 22.0 x 2.4 mm.

2.1.1 Real time kinematic

u-blox ZED-F9P high precision receiver takes GNSS precision to the next level:

- Delivers accuracy down to the centimeter level: 0.01m + 1 ppm CEP
- Fast time to first fix and robust performance with multi-band, multi-constellation reception
- Compatible with leading correction services for global coverage and versatility

Some typical applications for the ZED-F9P are shown below:



Figure 1: Typical applications for the ZED-F9P

2.1.1.1 Modes of operation

The ZED-F9P supports the following modes of operation:

1. ZED-F9P operating as a base: It provides RTCM correction data to a ZED-F9P rover, or to a network of ZED-F9P rovers.
2. ZED-F9P operating as a rover: It receives RTCM correction data from a ZED-F9P operating as a base, or from a virtual reference service provider operating a network of base receivers.

2.1.1.2 NTRIP - networked transport of RTCM via internet protocol

Networked Transport of RTCM via internet protocol, or NTRIP, is an open standard protocol for streaming differential data over the internet in accordance with specifications published by RTCM.

There are three major parts to the NTRIP system: The NTRIP client, the NTRIP server, and the NTRIP caster:

1. The NTRIP server is a PC or on-board computer running NTRIP server software communicating directly with a GNSS reference station. The NTRIP server serves as the

intermediary between the GNSS receiver (NTRIP Source) streaming RTCM data and the NTRIP caster.

2. The NTRIP caster is an HTTP server which receives streaming RTCM data from one or more NTRIP servers and in turn streams the RTCM data to one or more NTRIP clients via the internet.
3. The NTRIP client receives streaming RTCM data from the NTRIP caster to apply as real-time corrections to a GNSS receiver.

u-center GNSS evaluation software provides an NTRIP client and server application that can be used to easily evaluate a ZED-F9P base or rover. Typically a u-center NTRIP client connects over the internet to an NTRIP service provider. The u-center NTRIP client then provides the RTCM 3.3 corrections to a ZED-F9P rover connected to the local u-center application. Virtual reference service is also supported by the u-center NTRIP client.

2.2 Architecture

The ZED-F9P receiver provides all the necessary RF and baseband processing to enable multi-band, multi-constellation operation. The block diagram below shows the key functionality.

2.2.1 Block diagram

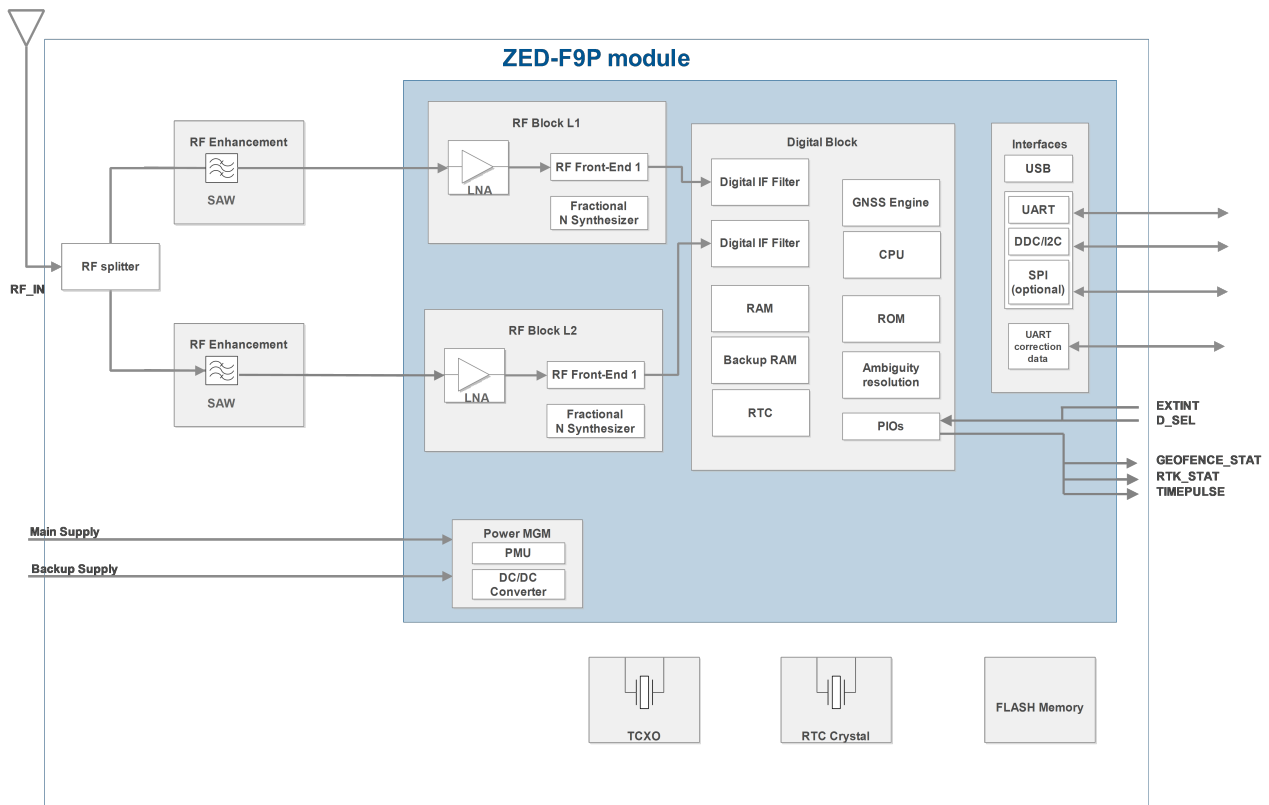

Figure 2: ZED-F9P block diagram

An active antenna is mandatory with the ZED-F9P.

2.2.2 Typical ZED-F9P application setups

Two application examples are illustrated below as typical system implementations. Both are representative of a simple "short baseline" set-up in which the base and rover receivers are within

a few hundred meters of each other. In [Figure 3](#) and [Figure 4](#) a ZED-F9P is used as a base station providing corrections to a ZED-F9P rover receiver.

Alternatively, the rover can use corrections provided over longer baselines from a correction stream distributed as a subscription service. This method can use a single fixed reference source which is local (within 50 km) to the rover receiver or via a virtual reference service in which corrections are synthesized for the rovers location.

The moving base feature also enables derivation of the vehicle orientation by mounting two or three GNSS receivers on the same vehicle platform, i.e. by fixing the position of the GNSS antennas relative to each other.

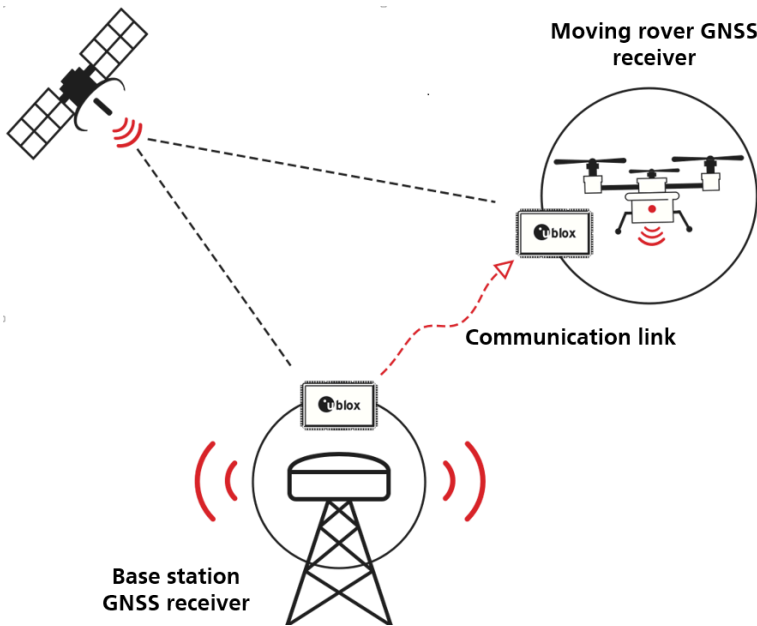

Figure 3: ZED-F9P base and rover in a short baseline drone application

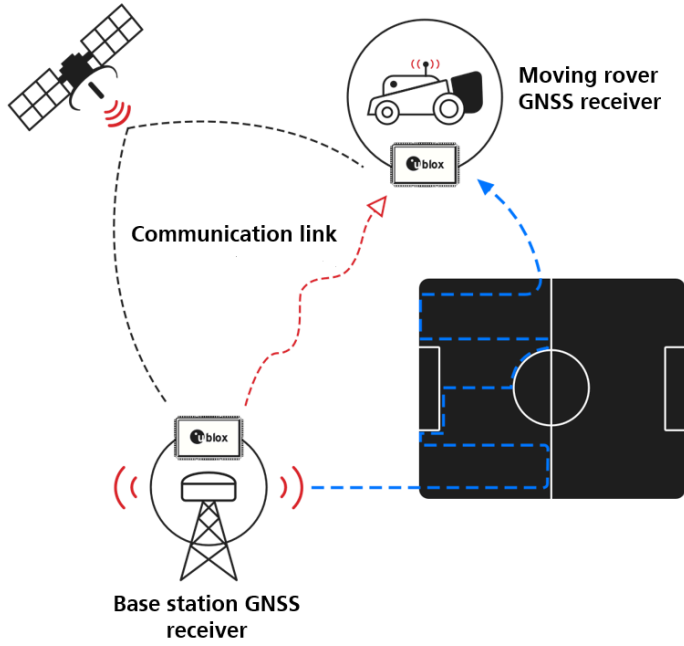

Figure 4: ZED-F9P base and rover in a short baseline robotic mower application

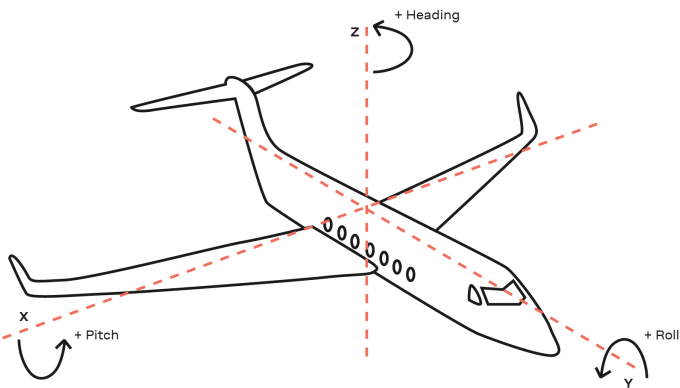

Figure 5: ZED-F9P orientation of a vehicle in space

3 Receiver functionality

This section describes the ZED-F9P operational features and their configuration.

3.1 Receiver configuration

The ZED-F9P is fully configurable with UBX configuration interface keys. The configuration database in the receiver's RAM holds the current configuration, which is used by the receiver at run-time. It is constructed on start-up of the receiver from several sources of configuration. The configuration interface and the available keys are described fully in the ZED-F9P Interface description [2].

A configuration setting stored in RAM remains effective until power-down or reset. If stored in BBR (battery backed RAM), the setting will be used as long as the backup battery supply remains. Configuration settings can be saved permanently in flash memory.



The configuration interface has changed from earlier u-blox positioning receivers. There is some backwards compatibility, however, users are strongly advised to adopt the configuration interface described in this document. See legacy UBX-CFG message fields reference section in the ZED-F9P Interface description [2].

Configuration interface settings are held in a database consisting of separate configuration items. An item is made up of a pair consisting of a key ID and a value. Related items are grouped together and identified under a common group name: CFG-GROUP-*; a convention used in u-center and within this document. Within u-center, a configuration group is identified as "Group name" and the configuration item is identified as the "item name" under the "Generation 9 Configuration View" - "Advanced Configuration" view.

The UBX messages available to change or poll the configurations are the UBX-CFG-VALSET, UBX-CFG-VALGET, and UBX-CFG-VALDEL messages. For more information about these messages and the configuration keys see the configuration interface section in the ZED-F9P Interface description [2].

3.1.1 Changing the receiver configuration

All configuration messages, including legacy UBX-CFG messages, will result in a UBX-ACK-ACK or UBX-ACK-NAK response. If several configuration messages are sent without waiting for this response then the receiver may pause processing of input messages until processing of a previous configuration message has been completed. When this happens a warning message "wait for cfg ACK" will be sent to the host.

3.1.2 Default GNSS configuration

The ZED-F9P default GNSS configuration is set as follows:

- GPS: L1C/A, L2C
- GLONASS: L1OF, L2OF
- Galileo: E1B/C, E5b
- BeiDou: B1I, B2I
- QZSS: L1C/A, L2C
- SBAS: L1C/A

For more information about the default configuration, see the ZED-F9P Interface description [2].

3.1.3 Default interface settings

Interface	Settings
UART1 output	38400 baud, 8 bits, no parity bit, 1 stop bit. NMEA protocol is enabled by default and GGA, GLL, GSA, GSV, RMC, VTG, TXT messages are output by default. UBX and RTCM 3.3 protocols are enabled by default but no output messages are enabled by default.
UART1 input	38400 baud, 8 bits, no parity bit, 1 stop bit. UBX, NMEA and RTCM 3.3 input protocols are enabled by default.
UART2 output	38400 baud, 8 bits, no parity bit, 1 stop bit. UBX protocol cannot be enabled. RTCM 3.3 protocol is enabled by default but no output messages are enabled by default. NMEA protocol is disabled by default.
UART2 input	38400 baud, 8 bits, no parity bit, 1 stop bit. UBX protocol cannot be enabled and will not receive UBX input messages. RTCM 3.3 protocol is enabled by default. NMEA protocol is disabled by default.
USB	Default messages activated as in UART1. Input/output protocols available as in UART1.
I2C	Fully compatible with the I2C ¹ industry standard, available for communication with an external host CPU or u-blox cellular modules, operated in slave mode only. Default messages activated as in UART1. Input/output protocols available as in UART1. Maximum bit rate 400 kb/s.
SPI	Allow communication to a host CPU, operated in slave mode only. Default messages activated as in UART1. Input/output protocols available as in UART1. SPI is not available unless D_SEL pin is set to low (see the D_SEL section).

Table 1: Default interface settings

With firmware versions HPG 1.00 or later UART2 can function as the main correction interface; RTCM 3.3 is the default input and output protocol. UART2 can also optionally be configured for NMEA input or output protocol.



Refer to the u-blox ZED-F9P Interface description [2] for information about further settings.



By default the ZED-F9P outputs NMEA 4.10 messages that include satellite data for all GNSS bands being received. This results in a high NMEA load output for each navigation period. Make sure the UART1 baud rate being used is sufficient for the selected navigation rate and the number of GNSS signals being received.

3.1.4 Basic receiver configuration

This section summarizes the basic receiver configuration most commonly used.

3.1.4.1 Communication interface configuration

Several configuration groups allow operation mode configuration of the various communication interfaces. These include parameters for the data framing, transfer rate and enabled input/output protocols. See [Communication interfaces](#) section for details. The configuration groups available for each interface are:

¹ I2C is a registered trademark of Philips/NXP

Interface	Configuration groups
UART1	CFG-UART1-*, CFG-UART1INPROT-*, CFG-UART1OUTPROT-*
UART2	CFG-UART2-*, CFG-UART2INPROT-*, CFG-UART2OUTPROT-*
USB	CFG-USB-*, CFG-USBINPROT-*, CFG-USBOUTPROT-*
I2C	CFG-I2C-*, CFG-I2CINPROT-*, CFG-I2COUTPROT-*
SPI	CFG-SPI-*, CFG-SPIINPROT-*, CFG-SPIOUTPROT-*

Table 2: Interface configurations

3.1.4.2 Message output configuration

The rate of the supported output messages is configurable.

If the rate configuration value is zero, then the corresponding message will not be output. Values greater than zero indicate how often the message is output.

For periodic output messages the rate relates to the event the message is related to. For example, the UBX-NAV-PVT (navigation position velocity and time solution) is related to the navigation epoch. If the rate of this message is set to one (1), it will be output for every navigation epoch. If the rate is set to two (2), it will be output every other navigation epoch. The rates of the output messages are individually configurable per communication interface. See the CFG-MSGOUT-* configuration group.

Some messages, such as UBX-MON-VER, are not periodic and will only be output as an answer to a poll request.

The UBX-INF-* and NMEA-Standard-TXT information messages are non-periodic output messages that do not have a message rate configuration. Instead they can be enabled for each communication interface via the CFG-INFMSG-* configuration group.



All message output is additionally subject to the protocol configuration of the communication interfaces. Messages of a given protocol will not be output until the protocol is enabled for output on the interface (see the previous section).

3.1.4.3 GNSS signal configuration

The GNSS constellations and bands are configurable with configuration keys from configuration group CFG-SIGNAL-*. Each GNSS constellation can be enabled or disabled independently. A GNSS constellation is considered to be enabled when the constellation enable key is set and at least one of the constellation's band keys is enabled.

ZED-F9P only supports certain combinations of constellations and bands. For all constellations, both L1 and L2 bands must either be enabled or disabled. BeiDou B2 is the exception (can either have BeiDou B1+B2 or B1-only). Unsupported combinations will be rejected with a UBX-ACK-NAK and the warning: "invalid sig cfg" will be sent via UBX-INF and NMEA-TXT messages (if enabled).

The following table shows possible configuration key combinations for the GPS constellation.

Constellation key CFG-SIGNAL-GPS_ENA	Band key CFG-SIGNAL-GPS_L1CA_ENA	Band key CFG-SIGNAL-GPS_L2C_ENA	Constellation enabled?
false (0)	false (0)	false (0)	no
false (0)	false (0)	true (1)	no
false (0)	true (1)	false (0)	no
false (0)	true (1)	true (1)	no
true (1)	false (0)	false (0)	no
true (1)	false (0)	true (1)	Unsupported combination

Constellation key	Band key	Band key	Constellation enabled?
CFG-SIGNAL-GPS_ENA	CFG-SIGNAL-GPS_L1CA_ENA	CFG-SIGNAL-GPS_L2C_ENA	
true (1)	true (1)	false (0)	Unsupported combination
true (1)	true (1)	true (1)	yes

Table 3: Example of possible values of configuration items for the GPS constellation

3.1.4.4 Antenna supervisor configuration

This section describes the antenna supervisor configuration, its use and restrictions.

The antenna supervisor is used to control an active antenna. The configuration of the antenna supervisor allows the following:

- Control voltage supply to the antenna, which allows the antenna supervisor to cut power to the antenna in the event of a short circuit or optimize power to the antenna in power save mode
- Detect a short circuit in the antenna and auto recover the antenna supply in such event
- Detect an open antenna, which can be used to tell if the antenna has been disconnected

See the table below for a description of the configuration items related to the antenna supervisor operation.

Configuration item	Description	Comments
CFG-HW-ANT_CFG_VOLTCTRL	Enable active antenna voltage control	
CFG-HW-ANT_CFG_SHORTDET	Enable short circuit detection	
CFG-HW-ANT_CFG_SHORTDET_POL	Short antenna detection polarity	Set to 1 if the required logic polarity is active-low (default)
CFG-HW-ANT_CFG_OPENDET	Enable open circuit detection	
CFG-HW-ANT_CFG_OPENDET_POL	Open antenna detection polarity	Set to 1 if the required logic polarity is active-low (default)
CFG-HW-ANT_CFG_PWRDOWN	Power down antenna supply if short circuit is detected	
CFG-HW-ANT_CFG_PWRDOWN_POL	Power down antenna logic polarity	Set to 1 if the required logic polarity is active-high (default)
CFG-HW-ANT_CFG_RECOVER	Enable auto recovery in the event of a short circuit	To use this feature, short circuit detection should be enabled. See CFG-HW-ANT_CFG_SHORTDET
CFG-HW-ANT_SUP_SWITCH_PIN	PIO-Pin (PIO number) used for switching antenna supply	It is recommended that you use the default PIO and assigned pin
CFG-HW-ANT_SUP_SHORT_PIN	PIO-Pin (PIO number) used for detecting a short-circuit in the antenna supply	It is recommended that you use the default PIO and assigned pin
CFG-HW-ANT_SHORT_THR	Defines the threshold for the antenna supervisor when a short status is detected.	Only applicable for the discrete antenna supervisor (based on MADC).
CFG-HW-ANT_OPEN_THR	Defines the threshold for the antenna supervisor when an open status is detected.	Only applicable for the discrete antenna supervisor (based on MADC).
CFG-HW-ANT_ENGINE	With this configuration key, the antenna supervisor engine can be selected.	Default value is "EXT".

Table 4: Antenna supervisor configuration

It is possible to obtain the status of the antenna supervisor through the UBX-MON-RF message. Moreover, any changes in the status of the antenna supervisor are reported to the host interface in the form of notice messages. See the ZED-F9P Interface description [2] for *antStatus* and *antPower* field description.

Status	Description
OFF	Antenna is off
ON	Antenna is on
DONTKNOW	Antenna power status is not known

Table 5: Antenna power status

3.1.5 RTK configuration

RTK technology introduces the concept of a base and a rover. In such a setup, the base sends corrections (complying with the RTCM 3.3 protocol) to the rover via a communication link. This enables the rover to compute its position relative to the base with high accuracy.

When operating as a rover, the ZED-F9P can receive RTCM 3.3 corrections from another ZED-F9P operating as a base, or via NTRIP from a virtual reference service provider operating a network of base receivers. In this mode, the receiver coordinates will be expressed in the datum used by the RTCM correction provider. For more information on this topic please refer to the [RTCM ITRF Geodetic models](#) section in the Appendix.

After describing the RTCM protocol and corresponding supported message types, this section describes how to configure the ZED-F9P high precision receiver as a base or rover receiver. This includes both the static base use case and the moving base use case.

See the ZED-F9P Moving Base application note [4] for more information on designing in, configuring and using a moving base setup.

3.1.5.1 RTCM corrections

RTCM is a binary data protocol for communication of GNSS correction information. The ZED-F9P high precision receiver supports RTCM as specified by RTCM 10403.3, Differential GNSS (Global Navigation Satellite Systems) Services – Version 3 (October 7, 2016).

The RTCM specification is currently at version 3.3 and RTCM version 2 messages are not supported by this standard.

To modify the RTCM input/output settings, see the configuration section in the u-blox ZED-F9P Interface description [2].

Users should be aware of the datum used by the correction source. The rover position will provide coordinates in the correction source reference frame. This may need to be taken into account when using the RTK rover position. See the [RTCM ITRF Geodetic models](#) section in the Appendix for more information.

3.1.5.2 List of supported RTCM input messages

Message type	Description
RTCM 1001	L1-only GPS RTK observables
RTCM 1002	Extended L1-only GPS RTK observables
RTCM 1003	L1/L2 GPS RTK observables
RTCM 1004	Extended L1/L2 GPS RTK observables
RTCM 1005	Stationary RTK reference station ARP
RTCM 1006	Stationary RTK reference station ARP with antenna height
RTCM 1007	Antenna descriptor
RTCM 1009	L1-only GLONASS RTK observables

² The terms base, base station, reference and reference station can be used interchangeably

Message type	Description
RTCM 1010	Extended L1-only GLONASS RTK observables
RTCM 1011	L1/L2 GLONASS RTK observables
RTCM 1012	Extended L1/L2 GLONASS RTK observables
RTCM 1033	Receiver and Antenna Description
RTCM 1074	GPS MSM4
RTCM 1075	GPS MSM5
RTCM 1077	GPS MSM7
RTCM 1084	GLONASS MSM4
RTCM 1085	GLONASS MSM5
RTCM 1087	GLONASS MSM7
RTCM 1094	Galileo MSM4
RTCM 1095	Galileo MSM5
RTCM 1097	Galileo MSM7
RTCM 1124	BeiDou MSM4
RTCM 1125	BeiDou MSM5
RTCM 1127	BeiDou MSM7
RTCM 1230	GLONASS code-phase biases
RTCM 4072.0	Reference station PVT (u-blox proprietary RTCM Message)

Table 6: ZED-F9P supported input RTCM version 3.3 messages

3.1.5.3 List of supported RTCM output messages

Message type	Description
RTCM 1005	Stationary RTK reference station ARP
RTCM 1074	GPS MSM4
RTCM 1077	GPS MSM7
RTCM 1084	GLONASS MSM4
RTCM 1087	GLONASS MSM7
RTCM 1094	Galileo MSM4
RTCM 1097	Galileo MSM7
RTCM 1124	BeiDou MSM4
RTCM 1127	BeiDou MSM7
RTCM 1230	GLONASS code-phase biases
RTCM 4072.0	Reference station PVT (u-blox proprietary RTCM Message)
RTCM 4072.1	Additional reference station information (u-blox proprietary RTCM Message)

Table 7: ZED-F9P supported output RTCM version 3.3 messages

3.1.5.4 Rover operation

In its default configuration, the ZED-F9P will attempt to provide the best positioning accuracy depending on the received correction data. It will enter RTK float mode as soon as it receives an input stream of RTCM correction messages. Once the rover has resolved the carrier phase ambiguities, it will enter RTK fixed mode. When in this mode, the relative position accuracy between base and rover can be expected to be correct to the cm-level. The time period between RTK float and RTK fixed operation is referred to as the convergence time. Note that the convergence time is affected by the baseline length as well as by multipath and satellite visibility at both rover and base station.

The ZED-F9P should receive RTCM corrections matching its GNSS signal configuration to function optimally. The rover requires both base station observation (MSM4 or MSM7 messages) and position message (RTCM 1005 or RTCM 1006) in order to attempt ambiguity fixes. The rover will attempt to provide RTK fixed operation when sufficient number of ambiguities are available. If phase lock on sufficient number of signals cannot be maintained, the rover will drop back to RTK float mode. The rover will continue to attempt to resolve carrier ambiguities and revert to RTK fixed mode once the minimum number of signals has been restored.

The RTK mode that an RTK rover operates in can be configured through the CFG-NAVHPG-DGNSSMODE configuration item. The two following RTK modes are available:

- RTK fixed: The rover will attempt to fix ambiguities whenever possible.
- RTK float: The rover will estimate the ambiguities as float but will make no attempts at fixing them.

The time after which RTCM data will be discarded can be configured through the CFG-NAVSPG-CONSTR_DGNSSSTO configuration item.

The received correction messages stream should comply with the following:

- The reference station ID in the reference station message (RTCM 1005 or 1006)) must match that used in the MSM observation messages. Otherwise, the rover cannot compute its position.
- In order to fix GLONASS ambiguities the correction stream must contain message 1230 or 1033. Otherwise, the carrier ambiguities will be estimated as float even when set to operate in RTK fixed mode. This will result in degraded performance, especially in challenging environments.

CFG-RTCM-DF003_IN can be used to configure the desired reference station ID and CFG-RTCM-DF003_IN_FILTER can be used to configure how strict the filtering should be (RELAXED is the recommended setting).

3.1.5.4.1 Message output in RTK mode

When operating in RTK rover mode users should take note of the modified information within the following NMEA and UBX messages:

- NMEA-GGA: The quality field will be 4 for RTK fixed and 5 for RTK float (see NMEA position fix flags in interface description). The age of differential corrections and base station ID will be set.
- NMEA-GLL, NMEA-VTG: The posMode indicator will be D for RTK float and RTK fixed (see NMEA position fix flags in interface description).
- NMEA-RMC, NMEA-GNS: The posMode indicator will be F for RTK float and R for RTK fixed (see NMEA position fix flags in interface description).
- UBX-NAV-PVT: The carrSoln flag will be set to 1 for RTK float and 2 for RTK fixed.
- UBX-NAV-RELPOSNED
 - The diffSoln and relPosValid flags will be set
 - The carrSoln flag will be set to 1 for RTK float and 2 for RTK fixed
- UBX-NAV-SAT
 - The diffCorr flag will be set for satellites with valid RTCM data
 - The rctmCorrUsed, prCorrUsed, and crCorrUsed flags will be set for satellites for which the RTCM corrections have been applied
- UBX-NAV-SIG
 - For signals to which the RTCM corrections have been applied, the correction source will be set to RTCM3 OSR and the crUsed, prCorrUsed, and crCorrUsed flags will be set
- UBX-NAV-STATUS
 - The diffSoln flag and the diffCorr flag will be set
 - The carrSoln flag will be set to 1 for RTK float and 2 for RTK fixed

- If the baseline exceeds 100km, a UBX-INF-WARNING will be output, e.g. "WARNING: DGNSS long baseline: 102.7 km"

An illustrated procedure for configuring a rover using u-center is shown in the [Appendix C.2](#).

3.1.5.5 Stationary base operation

The ZED-F9P high precision receiver default operation begins without producing any RTCM messages. RTCM observation messages will be streamed as soon as they are configured for output. However, any stationary reference position messages are output only when the base station position has been initialized and is operating in time mode. Time mode sets the receiver to operate as a stationary base station in fixed position and only time is estimated.

The following procedures can be used to initialize the base station position:

- Use the built-in survey-in procedure to estimate the position.
- Enter coordinates independently generated or taken from an accurate position such as a survey marker.
- Use in rover mode and feed the receiver corrections then enter the resultant estimated position coordinates as above.

3.1.5.5.1 Survey-in

Survey-in is a procedure that is carried out prior to entering time mode. It estimates the receiver position by building a weighted mean of all valid 3D position solutions.

Two major parameters are required when configuring:

- A **minimum observation time** defines the minimum observation time independent of the actual number of fixes used for the position estimate. Values can range from one day for high accuracy requirements to a few minutes for coarse position determination.
- A **3D position standard deviation** defines a limit on the spread of positions that contribute to the calculated mean.

Survey-in ends when both requirements are successfully met. The receiver begins operation in time mode and can output a base position message if configured. The survey-in status can be queried using the UBX-NAV-SVIN message.



The base station receiver should not be fed RTCM corrections while it is in survey-in mode. If a corrected position is desired, the base station coordinates should be pre-surveyed using RTCM corrections; the resultant position can be used to set the base station in fixed mode.

To configure a base station into survey-in mode (CFG-TMODE-MODE=SURVEY_IN), the following items are required:

Configuration item	Description
CFG-TMODE-MODE	Receiver mode (disabled, survey-in or fixed)
CFG-TMODE-SVIN_MIN_DUR	Survey-in minimum duration
CFG-TMODE-SVIN_ACC_LIMIT	Survey-in position accuracy limit

Table 8: Configuration items used for setting a base station into survey-in mode

3.1.5.5.2 Fixed position

Here the receiver position coordinates are entered manually. Any error in the base station position will directly translate into rover position errors. The base station position accuracy should therefore match or exceed the desired rover absolute position accuracy.

To configure Fixed mode (CFG-TMODE-MODE=FIXED), the following items are relevant:

Configuration item	Description
CFG-TMODE-MODE	Receiver mode (disabled or survey-in or fixed)
CFG-TMODE-POS_TYPE	Determines whether the ARP position is given in ECEF or LAT/LON/HEIGHT
CFG-TMODE-ECEF_X	ECEF X coordinate of the ARP position
CFG-TMODE-ECEF_Y	ECEF Y coordinate of the ARP position
CFG-TMODE-ECEF_Z	ECEF Z coordinate of the ARP position
CFG-TMODE-LAT	Latitude of the ARP position
CFG-TMODE-LON	Longitude of the ARP position
CFG-TMODE-HEIGHT	Height of the ARP position
CFG-TMODE-ECEF_X_HP	High-precision ECEF X coordinate of the ARP position
CFG-TMODE-ECEF_Y_HP	High-precision ECEF Y coordinate of the ARP position
CFG-TMODE-ECEF_Z_HP	High-precision ECEF Z coordinate of the ARP position
CFG-TMODE-LAT_HP	High-precision latitude of the ARP position
CFG-TMODE-LON_HP	High-precision longitude of the ARP position
CFG-TMODE-HEIGHT_HP	High-precision height of the ARP position
CFG-TMODE-FIXED_POS_ACC	Fixed position 3D accuracy estimate

Table 9: Configuration items used for setting a base station into fixed mode

Once the receiver is set in fixed mode, select the position format to use: either LLH or ECEF with optional high precision (mm) coordinates compared to the standard cm value.

For example, with CFG-TMODE-POS_TYPE=ECEF the base antenna position can be entered to cm precision using CFG-TMODE-ECEF_X, CFG-TMODE-ECEF_Y, CFG-TMODE-ECEF_Z. For high precision (mm) coordinates use CFG-TMODE-ECEF_X_HP, CFG-TMODE-ECEF_Y_HP, CFG-TMODE-ECEF_Z_HP. The same applies with corresponding coordinates used with CFG-TMODE-POS_TYPE=LLH.

The "3D accuracy" estimate in "Fixed Position" and the "Position accuracy limit" in "Survey-in" will affect the rover absolute position accuracy. Note that the availability of the position accuracy does not mitigate the error in the rover position, but only accounts for it when calculating the resulting positioning accuracy.



In stationary base station mode a current position check is made with respect to the fixed coordinates. If the result indicates the fixed position coordinates are incorrect, a UBX-INF-WARNING message "Base station position seems incorrect" is issued. The message is output when the coordinates are incorrect by more than ~50 m up to 25 km.



If the base station is moved during operation then new position coordinates must be configured.

An illustrated procedure for configuring a base receiver using u-center is shown in the [Appendix C.1](#).

3.1.5.5.3 Base station: RTCM output configuration

The desired RTCM messages must be selected and configured for the corresponding GNSS constellations received. The recommended list of RTCM output messages for a base operating in default GNSS configuration are:

- RTCM 1005 Stationary RTK reference station ARP
- RTCM 1074 GPS MSM4
- RTCM 1084 GLONASS MSM4
- RTCM 1094 Galileo MSM4
- RTCM 1124 BeiDou MSM4
- RTCM 1230 GLONASS code-phase biases

The configuration messages for these are shown in the [Table 10](#).

The following configuration items output the recommended messages for a default satellite constellation setting. Note that these are given for the UART1 interface:

Configuration item	Description
CFG-MSGOUT-RTCM_3X_TYPE1005_UART1	Output rate of the RTCM-3X-TYPE1005 message on port UART1: RTCM base station message
CFG-MSGOUT-RTCM_3X_TYPE1074_UART1	Output rate of the RTCM-3X-TYPE1074 message on port UART1: RTCM GPS MSM4 message
CFG-MSGOUT-RTCM_3X_TYPE1084_UART1	Output rate of the RTCM-3X-TYPE1084 message on port UART1: RTCM GLONASS MSM4 message
CFG-MSGOUT-RTCM_3X_TYPE1094_UART1	Output rate of the RTCM-3X-TYPE1094 message on port UART1: RTCM Galileo MSM4 message
CFG-MSGOUT-RTCM_3X_TYPE1124_UART1	Output rate of the RTCM-3X-TYPE1124 message on port UART1: RTCM BeiDou MSM4 message
CFG-MSGOUT-RTCM_3X_TYPE1230_UART1	Output rate of the RTCM-3X-TYPE1230 message on port UART1: RTCM GLONASS bias message

Table 10: Configuration items used for typical RTCM output configuration on UART1

CFG-RTCM-DF003_OUT can be used to configure the reference station ID that will be reported in all RTCM messages containing the RTCM DF003 data field.

The configuration of the RTCM 3.3 correction stream must be made with the following guidance:

- All observation messages must be broadcast at the same rate.
- The RTCM 3.3 correction stream must contain the GLONASS code-phase biases message (type 1230) or the Receiver Antenna Description message (type 1033) otherwise the GLONASS ambiguities can only be estimated as float, even in RTK fixed mode.
- The static reference station message (type 1005 or type 1006) does not need to be broadcast at the same rate as the observation messages however a rover will not be able to compute its position until it has received a valid reference station message.
- The correction stream should only contain one type of observation messages per constellation. When using a multi-constellation configuration, all constellations should use the same type of observation messages. Mixing MSM4 and MSM7 messages will possibly lead to incorrect setting of the multiple message bit.
- If the receiver is configured to output RTCM messages on several ports, they must all have the same RTCM configuration otherwise the MSM multiple message bit might not be set properly.

3.1.5.6 Base and rover configuration for moving base RTK operation

The moving base (MB) mode differs from the standard RTK operation in that the base station is no longer stationary at a pre-determined location. Both the reference station and rover receivers are allowed to move while computing an accurate vector between the receiver antennas. This mode enables the calculation of heading on dynamic or static platforms, plus provides a centimeter level accurate 3D vector for use in dynamic positioning applications, e.g. a UAV "follow me" feature.

In the MB RTK mode, the base and rover receivers are referred to as MB base and MB rover respectively.

This section describes how to configure the ZED-F9P high precision receiver in a moving base setup.

3.1.5.6.1 Base operation in MB RTK mode

In addition to the rules described in RTCM output configuration section above, the following moving base specific rules apply:

- The RTCM 3.3 stream must contain reference station message 4072.0 (position information) and MSM4 or MSM7 observation messages, otherwise the rover will be unable to operate in MB rover mode.
- Message 4072.1 (timing information) is no longer necessary for moving base rover and as such it is no longer used by a moving base rover. To reduce the bandwidth requirements between a moving base rover and a moving base, it is recommended to disable RTCM 4072.1 output on the base.
- Message 4072.0 must be sent for each epoch the MB base observations are sent.
- To ensure that the moving base processing works, the MB base and rover must use the same navigation update rate and measurement rate.

The desired RTCM messages must be selected and configured for the corresponding GNSS constellations received. The recommended list of RTCM output messages for a base operating in MB configuration are:

- RTCM 4072.0 Reference station PVT information
- RTCM 1074 GPS MSM4
- RTCM 1084 GLONASS MSM4
- RTCM 1094 Galileo MSM4
- RTCM 1124 BeiDou MSM4
- RTCM 1230 GLONASS code-phase biases

Additionally, while an MB receiver operates as a base, it is able to simultaneously:

- Apply RTCM 3.3 corrections and reach RTK fixed mode.
- Generate an MB correction stream for accompanying MB rover(s).

3.1.5.6.2 Rover operation in MB RTK mode

While the MB RTK solution aims at estimating the relative position with centimeter-level accuracy, the absolute position of each receiver is expected to be known with a standard GNSS accuracy of a few meters, unless the base is receiving RTCM 3.3 corrections.

In addition to the rules described in the rover operation section, the following moving base specific rules apply:

- A moving base receiver typically experiences worse GNSS tracking than a static base receiver in an open-sky environment and therefore the MB RTK performance may be degraded.
- The MB rover will wait as long as possible to compute a navigation solution, possibly lowering the navigation rate all the way to 1 Hz while doing so. If not time-matched observations are received in time, the receiver will flag the relative position as invalid.
- The achievable navigation update rate of the MB RTK solution is limited by the communication link latency. Latency here refers to the delay we have in getting the RTCM messages on the rover from the time they are sent from the base station.
- It is a good idea to try and minimize the latency in the communication link, especially if trying to achieve high navigation update rate. As a rule of thumb, the communication link latency should be less than the desired navigation update period minus 50 ms.
- If the communication link latency is too high to achieve the configured navigation update rate the receiver will lower the navigation update rate until it reaches 1 Hz.
- If the communication link latency is too high for 1 Hz rover operation, the receiver will declare the relative position as invalid.
- To ensure that the moving base processing works, the MB base and rover must use the same navigation update rate and measurement rate.

In addition to the modified output described in the rover operation section, the following moving base output message modifications will be observed:

UBX-NAV-RELPOSNEED:

- The isMoving flag will be set
- The relPosValid flag will be set if the rover managed to get the time-matched observations in time and process the moving base solution
- The length of the relative position vector and its accuracy will be output
- The heading for the relative position vector and its accuracy will be output
- The relPosHeadingValid flag will be set, unless the length of the relative position vector and/or its accuracy are not sufficient to reliably derive the heading information

3.1.6 Legacy configuration interface compatibility

There is some backwards-compatibility for the legacy UBX-CFG configuration messages. It is strongly recommended to adopt the new configuration interface, as the legacy configuration messages support will be removed in the future.

See Legacy UBX-CFG message fields reference section in the ZED-F9P Interface description [2].

3.1.7 Navigation configuration

This section presents various configuration options related to the navigation engine. These options can be configured through various configuration groups, such as CFG-NAVSPG-*, CFG-ODO-*, and CFG-MOT-*.

3.1.7.1 Platform settings

u-blox receivers support different dynamic platform models (see in the table below) to adjust the navigation engine to the expected application environment. These platform settings can be changed dynamically without performing a power cycle or reset. The settings improve the receiver's interpretation of the measurements and thus provide a more accurate position output. Setting the receiver to an unsuitable platform model for the given application environment is likely to result in a loss of receiver performance and position accuracy.

The dynamic platform model can be configured through the CFG-NAVSPG-DYNMODEL configuration item. The supported dynamic platform models and their details can be seen in [Table 11](#) and [Table 12](#) below.

Platform	Description
Portable (default)	Applications with low acceleration, e.g. portable devices. Suitable for most situations.
Stationary	Used in timing applications (antenna must be stationary) or other stationary applications. Velocity restricted to 0 m/s. Zero dynamics assumed.
Pedestrian	Applications with low acceleration and speed, e.g. how a pedestrian would move. Low acceleration assumed.
Automotive	Used for applications with equivalent dynamics to those of a passenger car. Low vertical acceleration assumed.
At sea	Recommended for applications at sea, with zero vertical velocity. Zero vertical velocity assumed. Sea level assumed.
Airborne <1g	Used for applications with a higher dynamic range and greater vertical acceleration than a passenger car. No 2D position fixes supported.
Airborne <2g	Recommended for typical airborne environments. No 2D position fixes supported.
Airborne <4g	Only recommended for extremely dynamic environments. No 2D position fixes supported.
Wrist	Only recommended for wrist-worn applications. Receiver will filter out arm motion.

Table 11: Dynamic platform models

Platform	Max altitude [m]	Max horizontal velocity [m/s]	Max vertical velocity [m/s]	Sanity check type	Max position deviation
Portable	12000	310	50	Altitude and velocity	Medium
Stationary	9000	10	6	Altitude and velocity	Small
Pedestrian	9000	30	20	Altitude and velocity	Small
Automotive	6000	100	15	Altitude and velocity	Medium
At sea	500	25	5	Altitude and velocity	Medium
Airborne <1g	50000	100	100	Altitude	Large
Airborne <2g	50000	250	100	Altitude	Large
Airborne <4g	50000	500	100	Altitude	Large
Wrist	9000	30	20	Altitude and velocity	Medium

Table 12: Dynamic platform model details

Dynamic platforms designed for high acceleration systems (e.g. airborne <2g) can result in a higher standard deviation in the reported position.

If a sanity check against a limit of the dynamic platform model fails, then the position solution is invalidated. Table 12 above shows the types of sanity checks which are applied for a particular dynamic platform model.

3.1.7.2 Navigation input filters

The navigation input filters in CFG-NAVSPG-* configuration group provide the input data of the navigation engine.

These settings are primarily for the initial standard 2D/3D only GNSS fix indication when not in RTK float/fixed mode.

Configuration item	Description
CFG-NAVSPG-FIXMODE	By default, the receiver calculates a 3D position fix if possible but reverts to 2D position if necessary (auto 2D/3D). The receiver can be forced to only calculate 2D (2D only) or 3D (3D only) positions.
CFG-NAVSPG-CONSTR_ALT, CFG-NAVSPG-CONSTR_ALTVAR	The fixed altitude is used if fixMode is set to 2D only. A variance greater than zero must also be supplied.
CFG-NAVSPG-INFIL_MINELEV	Minimum elevation of a satellite above the horizon in order to be used in the navigation solution. Low elevation satellites may provide degraded accuracy, due to the long signal path through the atmosphere.
CFG-NAVSPG-INFIL_NCNOTHRS, CFG-NAVSPG-INFIL_CNOTHRS	A navigation solution will only be attempted if there are at least the given number of SVs with signals at least as strong as the given threshold.

Table 13: Navigation input filter parameters

If the receiver only has three SVs for calculating a position, the navigation algorithm uses a constant altitude to compensate for the missing fourth SV. When a SV is lost after a successful 3D fix (min. four SVs available), the altitude is kept constant at the last known value. This is called a 2D fix.

u-blox receivers do not calculate any navigation solution with less than three SVs.

3.1.7.3 Navigation output filters

The result of a navigation solution is initially classified by the fix type (as detailed in the `fixType` field of UBX-NAV-PVT message). This distinguishes between failures to obtain a fix at all ("No Fix") and cases where a fix has been achieved, which are further subdivided into specific types of fixes (e.g. 2D, 3D, dead reckoning).

The ZED-F9P firmware does not support the dead reckoning position fix type.

Where a fix has been achieved, a check is made to determine whether the fix should be classified as valid or not. A fix is only valid if it passes the navigation output filters as defined in CFG-NAVSPG-OUTFIL. In particular, both PDOP and accuracy values must be below the respective limits.

 Important: Users are recommended to check the `gnssFixOK` flag in the UBX-NAV-PVT or the NMEA valid flag. Fixes not marked valid should not be used.

UBX-NAV-STATUS message also reports whether a fix is valid in the `gpsFixOK` flag. These messages have only been retained for backwards compatibility and users are recommended to use the UBX-NAV-PVT message.

The CFG-NAVSPG-OUTFIL_TDOP and CFG-NAVSPG-OUTFIL_TACC configuration items also define TDOP and time accuracy values that are used in order to establish whether a fix is regarded as locked to GNSS or not, and as a consequence of this, which time pulse setting has to be used. Fixes that do not meet both criteria will be regarded as unlocked to GNSS, and the corresponding time pulse settings of CFG-TP-* configuration group will be used to generate a time pulse.

 When in RTK float/fixed mode there are no navigation output filter settings for this mode. This is handled internally in the RTK core.

3.1.7.3.1 Speed (3D) low-pass filter

The CFG-ODO-OUTLPVEL configuration item offers the possibility to activate a speed (3D) low-pass filter. The output of the speed low-pass filter is published in the UBX-NAV-VELNED message (`speed` field). The filtering level can be set via the CFG-ODO-VELLPGAIN configuration item and must be comprised between 0 (heavy low-pass filtering) and 255 (weak low-pass filtering).

 The internal filter gain is computed as a function of speed. Therefore, the level as defined in the CFG-ODO-VELLPGAIN configuration item defines the nominal filtering level for speeds below 5 m/s.

3.1.7.3.2 Course over ground low-pass filter

The CFG-ODO-OUTLPCOG configuration item offers the possibility to activate a course over ground low-pass filter when the speed is below 8 m/s. The output of the course over ground (also named heading of motion 2D) low-pass filter is published in the UBX-NAV-PVT message (`headMot` field), UBX-NAV-VELNED message (`heading` field), NMEA-RMC message (`cog` field) and NMEA-VTG message (`cogt` field). The filtering level can be set via the CFG-ODO-COGLPGAIN configuration item and must be comprised between 0 (heavy low-pass filtering) and 255 (weak low-pass filtering).

 The filtering level as defined in the CFG-ODO-COGLPGAIN configuration item defines the filter gain for speeds below 8 m/s. If the speed is higher than 8 m/s, no course over ground low-pass filtering is performed.

3.1.7.3.3 Low-speed course over ground filter

The CFG-ODO-USE_COG activates this feature and the CFG-ODO-COGMAXSPEED, CFG-ODO-COGMAXPOSACC configuration items offer the possibility to configure a low-speed course over ground filter (also named heading of motion 2D). This filter derives the course over ground from position at very low speed. The output of the low-speed course over ground filter is published in the UBX-NAV-PVT message (`headMot` field), UBX-NAV-VELNED message (`heading` field), NMEA-RMC message (`cog` field) and NMEA-VTG message (`cogt` field). If the low-speed course over ground filter is not configured, then the course over ground is computed as described in section [Freezing the course over ground](#).

3.1.7.4 Static hold

Static hold mode allows the navigation algorithms to decrease the noise in the position output when the velocity is below a pre-defined "Static Hold Threshold". This reduces the position wander caused

by environmental factors such as multi-path and improves position accuracy especially in stationary applications. By default, static hold mode is disabled.

If the speed drops below the defined "Static Hold Threshold", the static hold mode will be activated. Once static hold mode has been entered, the position output is kept static and the velocity is set to zero until there is evidence of movement again. Such evidence can be velocity, acceleration, changes of the valid flag (e.g. position accuracy estimate exceeding the position accuracy mask, see also section [Navigation output filters](#)), position displacement, etc.

The CFG-MOT-GNSSDIST_THRS configuration item additionally allows for configuration of distance threshold. If the estimated position is farther away from the static hold position than this threshold, static mode will be quit. The CFG-MOT-GNSSSPEED_THRS configuration item allows you to set a speed that the static hold will release.

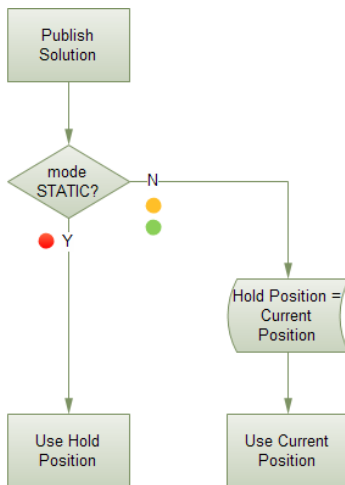

Figure 6: Position publication in static hold mode

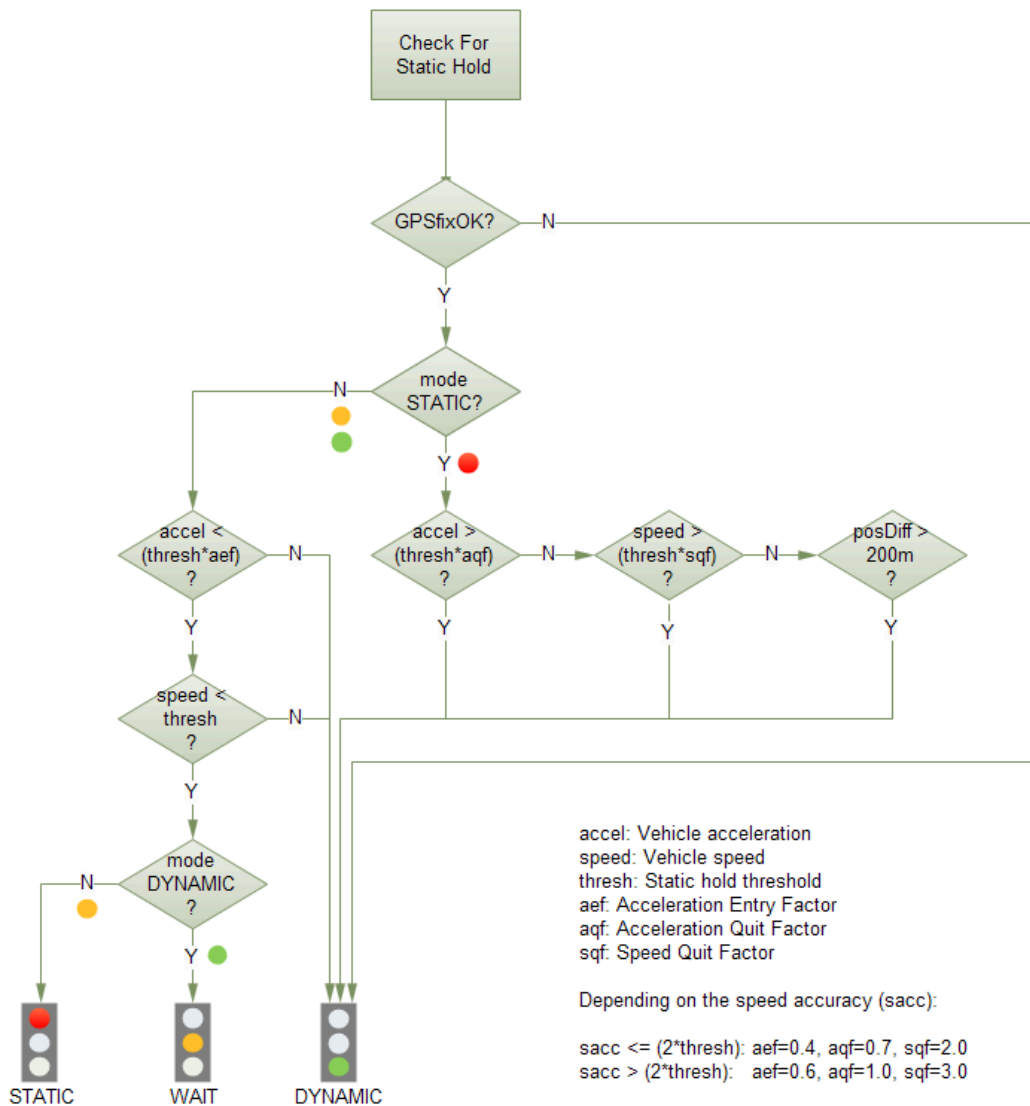

Figure 7: Flowchart of the static hold mode

3.1.7.5 Freezing the course over ground

If the low-speed course over ground filter is deactivated or inactive (see section [Low-speed course over ground filter](#)), the receiver derives the course over ground from the GNSS velocity information. If the velocity cannot be calculated with sufficient accuracy (e.g., with bad signals) or if the absolute speed value is very low (under 0.1 m/s) then the course over ground value becomes inaccurate too. In this case the course over ground value is frozen, i.e. the previous value is kept and its accuracy is degraded over time. These frozen values will not be output in the NMEA messages NMEA-RMC and NMEA-VTG unless the NMEA protocol is explicitly configured to do so (see NMEA protocol configuration in the ZED-F9P Interface description [2]).

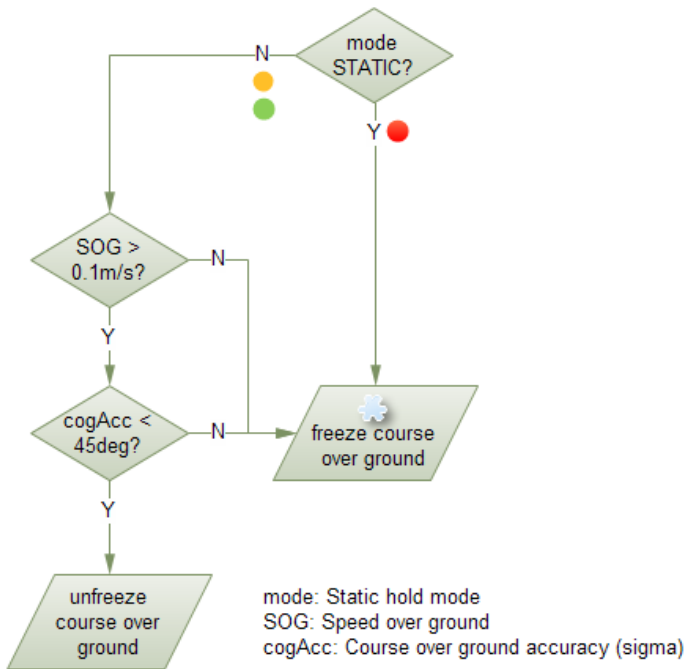

Figure 8: Flowchart of the course over ground freezing

3.2 SBAS

ZED-F9P high precision receiver is capable of receiving multiple SBAS signals concurrently, even from different SBAS systems (WAAS, EGNOS, MSAS, etc.). They can be tracked and used for navigation simultaneously, every SBAS satellite that broadcasts ephemeris or almanac information can be used for navigation, just like a normal GNSS satellite.

For receiving correction data, the ZED-F9P high precision receiver automatically chooses the best SBAS satellite as its primary source. It will select only one since the information received from other SBAS satellites is redundant and/or could be inconsistent. The selection strategy is determined by the proximity of the satellites, the services offered by the satellite, the configuration of the receiver (Testmode allowed/disallowed, Integrity enabled/disabled) and the signal link quality to the satellite.

If corrections are available from the chosen SBAS satellite and used in the navigation calculation, the differential status will be indicated in several output messages such as UBX-NAV-PVT, UBX-NAV-STATUS, UBX-NAV-SAT, NMEA-GGA, NMEA-GLL, NMEA-RMC and NMEA-GNS (see ZED-F9P Interface description [2]). The message UBX-NAV-SBAS provides detailed information about which corrections are available and applied.

The most important SBAS feature for accuracy improvement is Ionosphere correction. The measured data from regional RIMS stations are combined to make a TEC (Total Electron Content) Map. This map is transferred to the receiver via the satellites to allow a correction of the ionosphere error on each received satellite.

Message type	Message content	Source
0(0/2)	Test mode	All
1	PRN mask assignment	Primary
2, 3, 4, 5	Fast corrections	Primary
6	Integrity	Primary
7	Fast correction degradation	Primary

Message type	Message content	Source
9	Satellite navigation (ephemeris)	All
10	Degradation	Primary
12	Time offset	Primary
17	Satellite almanac	All
18	Ionosphere grid point assignment	Primary
24	Mixed fast / long term corrections	Primary
25	Long term corrections	Primary
26	Ionosphere delays	Primary

Table 14: Supported SBAS messages

Each satellite services a specific region and its correction signal is only useful within that region. Planning is crucial to determine the best possible configuration, especially in areas where signals from different SBAS systems can be received:

- **Example 1 - SBAS receiver in North America:** In the eastern parts of North America, make sure that EGNOS satellites do not take preference over WAAS satellites. The satellite signals from the EGNOS system should be disallowed by using the PRN mask.
- **Example 2 - SBAS receiver in Europe:** Some WAAS satellite signals can be received in the western parts of Europe, therefore it is recommended that the satellites from all but the EGNOS system should be disallowed using the PRN mask.



Although u-blox receivers try to select the best available SBAS correction data, it is recommended to configure them to disallow using unwanted SBAS satellites.

To configure the SBAS functionalities use the CFG-SBAS-* configuration group.

Parameter	Description
CFG-SIGNAL-SBAS_ENA	Enabled/disabled status of the SBAS subsystem
CFG-SBAS-USE_TESTMODE	Allow/disallow SBAS usage from satellites in test mode
CFG-SBAS-USE_RANGING	Use the SBAS satellites for navigation (ranging)
CFG-SBAS-USE_DIFFCORR	Combined enable/disable switch for fast-, long-term and ionosphere corrections
CFG-SBAS-USE_INTEGRITY	Apply integrity information data
CFG-SBAS-PRNSCANMASK	Allows selectively enabling/disabling SBAS satellites

Table 15: SBAS configuration parameters



SBAS is only used if no RTCM correction services are available. If the connection stream is lost during the operation, the receiver will switch to use the SBAS corrections after the time set in CFG-NAVSPG-CONSTR_DGNSSTO (60 s by default) has elapsed.

When the receiver switches from an RTK to a standard position solution, the reference frame of the output position will switch from that of the RTK corrections to that of the standard position solution. For an SBAS solution this reference frame will be aligned within a few cm of WGS84 (and modern ITRF realizations).

3.3 QZSS SLAS

QZSS SLAS (Sub-meter Level Augmentation Service) is an augmentation technology, which provides correction data for pseudoranges of GPS, QZSS, and other major GNSS satellites. The correction stream is transmitted on the L1S signal at the L1 frequency (1575.42 MHz).

For more information on QZSS SLAS, visit the web site qzss.go.jp/en/.



QZSS SLAS is only used if no RTCM correction services are available. If the connection stream is lost during the operation, the receiver will switch to use the SLAS corrections after the time set in CFG-NAVSPG-CONSTR_DGNSSTO (60 s by default) has elapsed.

3.3.1 Features

Multiple QZSS SLAS signals can be received simultaneously.

When receiving QZSS SLAS correction data, the ZED-F9P high precision receiver will autonomously select the best QZSS satellite. The selection strategy is determined by the quality of the QZSS L1S signals, the receiver configuration (test mode allowed or not), and the location of the receiver with respect to the QZSS SLAS coverage area. When outside of this coverage area, the receiver will likely fall back to using SBAS corrections.

If QZSS SLAS corrections are used in the navigation solution, the differential status will be indicated in several output messages such as UBX-NAV-PVT, UBX-NAV-STATUS, UBX-NAV-SAT, NMEA-GGA, NMEA-GLL, NMEA-RMC and NMEA-GNS (see ZED-F9P Interface description [2]). The message UBX-NAV-SLAS provides detailed information about which corrections are available and applied.

Message type	Message content
0	Test mode
47	Monitoring station information
48	PRN mask
49	Data issue number
50	DGPS correction
51	Satellite health

Table 16: Supported QZSS L1S SLAS messages for navigation enhancing

3.3.2 Configuration

To enable support for the necessary QZSS L1S signal, use the CFG-SIGNAL-QZSS_L1S_ENA configuration item. To configure further QZSS SLAS functionalities, use the CFG-QZSS-USE_SLAS* configuration items.

Parameter	Description
CFG-QZSS-USE_SLAS_DGNSS	Apply QZSS SLAS corrections
CFG-QZSS-USE_SLAS_TESTMODE	Allow the correction provided by QZSS satellites that are in test mode
CFG-QZSS-USE_SLAS_RAIM_UNCORR	If this configuration is set, the receiver will try to estimate the position by using only corrected measurements; if all corrected measurements are not available, it won't use any corrections. If this configuration is not set, the receiver will mix corrected and uncorrected measurements for the navigation solution.

Table 17: QZSS SLAS configuration parameters



If the RAIM option is set, other GNSS time systems than the QZSS time system cannot be observed by measurements.

3.4 Geofencing

3.4.1 Introduction

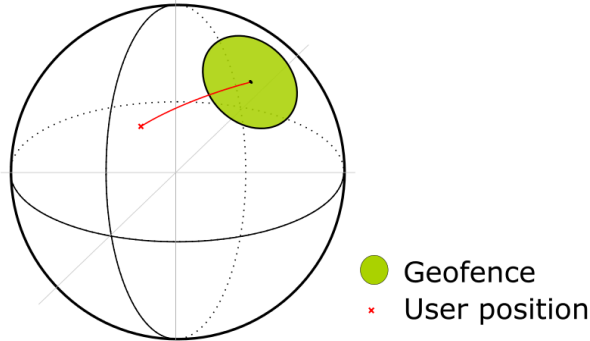

Figure 9: Geofence

The geofencing feature allows for the configuration of up to four circular areas (geofences) on the Earth's surface. The receiver will then evaluate for each of these areas whether the current position lies within the area or not and signal the state via UBX messaging and PIO toggling.

3.4.2 Interface

Geofencing can be configured using the CFG-GEOFENCE-* configuration group. The geofence evaluation is active whenever there is at least one geofence configured.

The current state of each geofence plus the combined state is output in UBX-NAV-GEOFENCE with every navigation epoch.

Additionally the user can configure the receiver to output the combined geofence state on a physical pin (assigned to a PIO being used for geofence state indication).

3.4.3 Geofence state evaluation

With every navigation epoch the receiver will evaluate the current solution's position versus the configured geofences. There are three possible outcomes for each geofence:

- *Inside* - The position is inside the geofence with the configured confidence level
- *Outside* - The position lies outside of the geofence with the configured confidence level
- *Unknown* - There is no valid position solution or the position uncertainty does not allow for unambiguous state evaluation

The position solution uncertainty (standard deviation) is multiplied with the configured confidence sigma level number and taken into account when evaluating the geofence state (red circle in figure below).

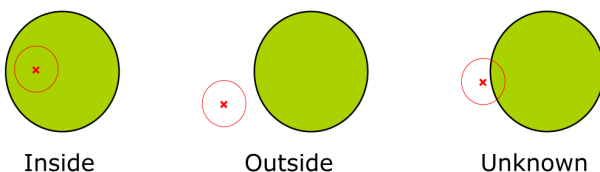

Figure 10: Geofence states

The combined state for all geofences is evaluated as the combination (Union) of all geofences:

- *Inside* - The position lies inside of at least one geofence
- *Outside* - The position lies outside of all geofences
- *Unknown* - All remaining states

A pin is made available to indicate the status of the geofence. See the [GEOFENCE_STAT interface](#).

3.4.4 Using a PIO for geofence state output

This feature can be used for example for waking up a sleeping host when a defined geofence condition is reached. The receiver will toggle the assigned pin according to the *combined* geofence state. Due to hardware restrictions, the geofence unknown state is not configurable and is always be represented as HIGH. If the receiver is in software backup or in a reset, the pin will go to HIGH accordingly. The meaning of the LOW state can be configured using the CFG-GEOFENCE-PINPOL configuration item.



The CFG-GEOFENCE-PIN configuration item refers to a PIO and not a physical device pin. The PIO number must be set so that it is mapped to the assigned geofence state device pin. The ZED-F9P is assigned PIO3 that is assigned to module pin 19.

3.5 Logging

3.5.1 Introduction

The logging feature allows position fixes and arbitrary byte strings from the host to be logged in flash memory attached to the receiver. Logging of position fixes happens independently of the host system, and can continue while the host is powered down.

The following table lists all the logging-related messages:

Message	Description
UBX-LOG-CREATE	Creates a log file and activates the logging system
UBX-LOG-ERASE	Erases a log file and deactivates the logging subsystem
UBX-LOG-INFO	Provides information about the logging system
UBX-LOG-STRING	Enables a host process to write a string of bytes to the log file

Table 18: Logging control and configuration messages

Message	Description
UBX-LOG-RETRIEVE	Starts the log retrieval process
UBX-LOG-RETRIEVEPOS	A position log entry returned by the receiver
UBX-LOG-RETRIEVEPOSEXTRA	Odometer position data
UBX-LOG-RETRIEVESTRING	A byte string log entry returned by the receiver
UBX-LOG-FINDTIME	Finds the index of the first entry (given time)

Table 19: Logging retrieval messages

3.5.2 Setting the logging system up

An empty log can be created using the UBX-LOG-CREATE message and a log can be deleted with the UBX-LOG-ERASE message. The logging system will only be running if a log is in existence, so most logging messages will be rejected with a UBX-ACK-NAK message if there is no log present. Only one log can be created at any one time, therefore a UBX-ACK-NAK message will be returned, if a log already exists. The message specifies the maximum size of the log in bytes (with some pre-set values provided). Both the logging subsystem and the receiver file-store have implementation overheads, so total space available for log entries will be somewhat smaller than the size specified.

UBX-LOG-CREATE also allows the log to be specified as a circular log. If the log is circular, a set of older log entries will be deleted when it fills up, and the space freed up is used for new log entries. By contrast, if a non-circular log becomes full then new entries which do not fit will be rejected. UBX-LOG-CREATE also causes the logging system to start up so that further logging messages can be processed. The logging system will start up automatically on power-up if there is a log in existence. The log will remain in the receiver until specifically erased using the UBX-LOG-ERASE message.

The CFG-LOGFILTER-* configuration group controls whether logging of entries is currently enabled and selects position fix messages for logging.

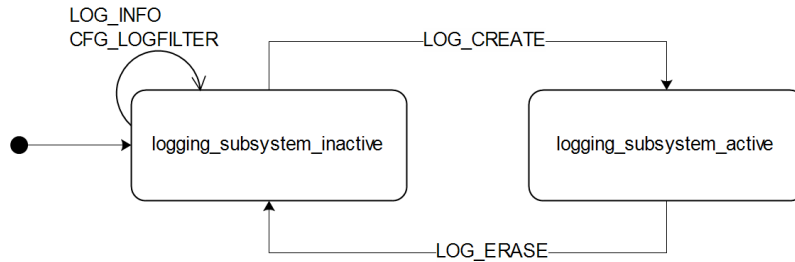

Figure 11: The top level active/inactive states of the logging subsystem

3.5.3 Information about the log

The receiver can be polled for a UBX-LOG-INFO message which will give information about the log. This will include the maximum size that the log can grow to (which, due to overheads, will be smaller than that requested in UBX-LOG-CREATE) and the amount of log space currently occupied. It will also report the number of entries currently in the log together with the time and date of the newest and oldest messages which have a valid time stamp.

Log entries are compressed and have housekeeping information associated with them, so the actual space occupied by log messages may be difficult to predict. The minimum size for a position fix entry is 9 bytes and the maximum 24 bytes, the typical size is 10 or 11 bytes. If the odometer is enabled then this will use at least another three bytes per fix.

Each log also has a fixed overhead which is dependent on the log type. The approximate size of this overhead is shown in the following table.

Log type	Overhead
circular	Up to 40 kB
non-circular	Up to 8 kB

Table 20: Log overhead size

The number of entries that can be logged in any given flash size can be estimated as follows:

Approx. number of entries = (flash size available for logging - log overhead)/typical entry size

For example, if 1500 kB of flash is available for logging (after other flash usage such as the firmware image is taken into account) a non-circular log would be able to contain approximately 139000 entries: $((1500 \times 1024) - (8 \times 1024)) / 11 = 138891$.

3.5.4 Recording

The CFG-LOGFILTER-RECORD_ENA configuration item must be set to *true* to enable recording into the log. Nothing will be recorded if recording is disabled, otherwise position fix and UBX-LOG_STRING entries can be recorded. When recording is enabled an entry will also be created from each UBX-LOG-STRING message. These will be timestamped if the receiver has current knowledge of time.

The CFG-LOGFILTER-* configuration group has several values which can be used to select position fix entries for logging. If CFG-LOGFILTER-APPLY_ALL_FILTERS is *false*, then all position fixes will be logged (subject to a maximum rate of 1 Hz). Otherwise, a position is logged if any of the or if all of MIN_INTERVAL, TIME_THRS, SPEED_THRS or POSITION_THRS thresholds are exceeded. If a threshold is set to zero it is ignored.

Position fixes are only recorded if a valid fix is obtained. Failed and invalid fixes are not recorded. Position fixes are compressed to reduce the amount of flash space used. In order to improve the compression, the fix values are rounded. This means that the values returned by the logging system may differ slightly from those that are gathered in real time.

The recorded data for a fix comprises:

- The time and date of the fix recorded to a precision of one second.
- Latitude and longitude to a precision of one millionth of a degree. Depending on position on Earth this is a precision in the order of 0.1 m.
- Altitude (height above mean sea level) to a precision of 0.1 m. Entries with an altitude lower than -470 m (lower than the lowest point on earth) or higher than 20,000 m may not be recorded in the log.
- Ground speed to a precision of 1 cm/s.
- The fix type (only successful fix types, since these are the only ones recorded).
- The number of satellites used in the fix is recorded, but there is a maximum count which can be recorded. If the actual count exceeds this maximum count then the maximum count will be recorded. If a log entry is retrieved with a satellite count equal to the maximum this means that value or more. The maximum count is 51.
- A horizontal accuracy estimate is recorded to give an indication of fix quality. This is an approximate compressed representation of the accuracy as determined by the fix process. Any accuracy less than 0.7 m will be recorded as 0.7 m and any value above 1 km will be recorded as 1 km. Within these limits, the recorded accuracy will always be greater than the fix accuracy number (by up to 40%).
- Heading to a precision of one degree.
- Odometer distance data (if odometer is enabled).

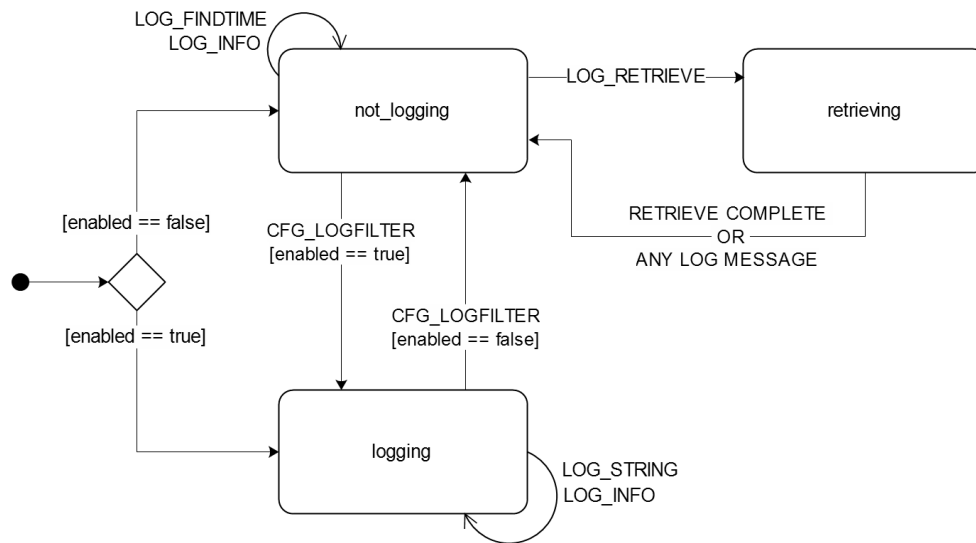

Figure 12: The states of the active logging subsystem

3.5.5 Retrieval

UBX-LOG-RETRIEVE starts the process which allows the receiver to output log entries. UBX-LOG-INFO may be helpful to a host system in order to understand the current log status before retrieval is started.

Once retrieval has started, one message will be output from the receiver for each log entry requested. Sending any logging message to the receiver during retrieval will cause the retrieval to stop before the message is processed.

To maximize the speed of transfer it is recommended that a high communications data rate is used and GNSS processing is stopped during the transfer (see UBX-CFG-RST).

UBX-LOG-RETRIEVE can specify a start-entry index and entry-count. The maximum number of entries that can be returned in response to a single UBX-LOG-RETRIEVE message is 256. If more entries than this are required the message will need to be sent multiple times with different startEntry indices. It is may be useful to stop recording via CFG_LOGFILTER-RECORD_ENA while retrieving log entries from a circular log to avoid deletion of the requested entries between the request and transmission.

The receiver will send a UBX-LOG-RETRIEVEPOS message for each position fix log entry and a UBX-LOGRETRIEVESTRING message for each string log entry. If the odometer was enabled at the time a position was logged, then a UBX-LOG-RETRIEVEPOSEXTRA will also be sent. Messages will be sent in the order in which they were logged, so UBX-LOG-RETRIEVEPOS and UBX-LOG-RETRIEVESTRING messages may be interspersed in the message stream.

The UBX-LOG-FINDTIME message can be used to search a log for the index of the first entry less than or equal to the given time. This index can then be used with the UBX-LOG-RETRIEVE message to provide timebased retrieval of log entries.

3.5.6 Command message acknowledgment

Some log operations may take a long time to execute because of the time taken to write to flash memory. The time for some operations may be unpredictable since the number and timing of flash operations may vary. In order to allow host software to synchronize to these delays logging

messages will always produce a response. This will be UBX-ACK-NAK in case of error, otherwise UBX-ACK-ACK unless there is some other defined response to the message.

It is possible to send a small number of logging commands without waiting for acknowledgment, since there is a command queue, but this risks confusion between the acknowledgments for the commands. Also a command queue overflow would result in commands being lost.

3.6 Communication interfaces

ZED-F9P provides UART1, SPI, I2C and USB interfaces for communication with a host CPU. The interfaces are configured via the configuration interface which is described in the ZED-F9P interface description [2].

Each protocol can be enabled on several ports at the same time (multi-port capability) with individual settings (e.g. baud rate, message rates, etc.) for each port. Furthermore, more than one protocol can be enabled on a single port at the same time (multi-protocol capability).

Port #	Port # in MON-COMMS	Electrical interface
0	0x0000	I2C
1	0x0001	UART1
2	0x0102	UART2
3	0x0003	USB
4	0x0004	SPI

Table 21: Port number assignment



It is important to isolate interface pins when VCC is removed. They can be allowed to float or they can be connected to a high impedance.

Example isolation circuit is shown below.

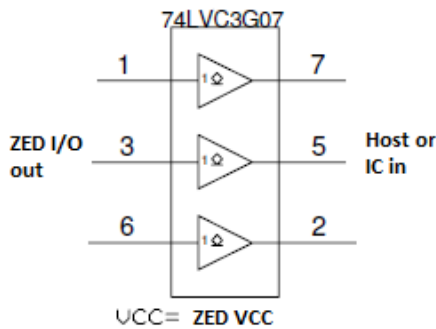

Figure 13: ZED-F9P output isolation

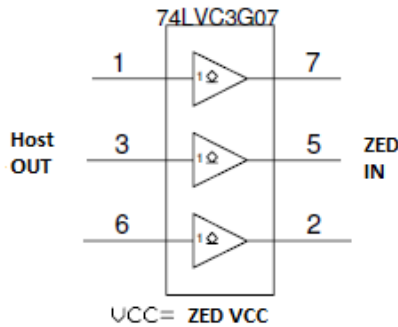

Figure 14: ZED-F9P input isolation

3.6.1 UART interfaces

ZED-F9P includes 2 UART ports.

UART1 can be used as a host interface. It supports a configurable baud rate and protocol selection.

UART2 is available as an optional stand-alone RTCM input interface. It cannot not be used as a host interface.

The serial ports consist of an RX and a TX line. Neither handshaking signals nor hardware flow control signals are available. These serial ports operate in asynchronous mode. The baud rates can be configured individually for each serial port. However, there is no support for setting different baud rates for reception and transmission.



The UART RX interface will be disabled when more than 100 frame errors are detected during a one-second period. This can happen if the wrong baud rate is used or the UART RX pin is grounded. An error message appears when the UART RX interface is re-enabled at the end of the one-second period.

Baud rate	Data bits	Parity	Stop bits
9600	8	none	1
19200	8	none	1
38400	8	none	1
57600	8	none	1
115200	8	none	1
230400	8	none	1
460800	8	none	1
921600	8	none	1

Table 22: Possible UART interface configurations



The default baud rate is 38400 baud. To prevent buffering problems it is recommended not to run at a lower baud rate than the default.

Note that for protocols such as NMEA or UBX, it does not make sense to change the default word length values (data bits) since these properties are defined by the protocol and not by the electrical interface.

If the amount of data configured is too much for a certain port's bandwidth (e.g. all UBX messages output on a UART port with a baud rate of 9600), the buffer will fill up. Once the buffer space is

exceeded, new messages to be sent will be dropped. To prevent message loss, the baud rate and communication speed or the number of enabled messages should be carefully selected so that the expected number of bytes can be transmitted in less than one second.

3.6.2 I2C interface

An I2C interface is available for communication with an external host CPU or u-blox cellular modules. The interface can be operated in slave mode only. The I2C protocol and electrical interface are fully compatible with the fast-mode of the I2C industry standard. Since the maximum SCL clock frequency is 400 kHz, the maximum transfer rate is 400 kb/s. The SCL and SDA pins have internal pull-up resistors which should be sufficient for most applications. However, depending on the speed of the host and the load on the I2C lines additional external pull-up resistors may be necessary.

 To use the I2C interface D_SEL pin must be left open.

 In designs where the host uses the same I2C bus to communicate with more than one u-blox receiver, the I2C slave address for each receiver must be configured to a different value. Typically most u-blox receivers are configured to the same default I2C slave address value. To poll or set the I2C slave address, use the CFG-I2C-ADDRESS configuration item (see ZED-F9P Interface description [2]).

The CFG-I2C-ADDRESS configuration item is an 8-bit value containing the I2C slave address in 7 most significant bits, and the read/write flag in the least significant bit.

3.6.2.1 I2C register layout

The I2C interface allows 256 registers to be addressed. As shown in [Figure 15](#), only three of these are currently implemented.

The data registers 0 to 252 at addresses 0x00 to 0xFC contain information reserved, the result from their reading is currently undefined. The data registers 0 to 252 are 1 byte wide.

At addresses 0xFD and 0xFE it is possible to read the currently available number of bytes.

The register at address 0xFF allows the data stream to be read. If there is no data awaiting transmission from the receiver, then this register delivers value 0xFF, which cannot be the first byte of a valid message. If the message data is ready for transmission, the successive reads of register 0xFF will deliver the waiting message data.

 Do not use registers 0x00 to 0xFC. They are reserved for future use and they do not currently provide any meaningful data.

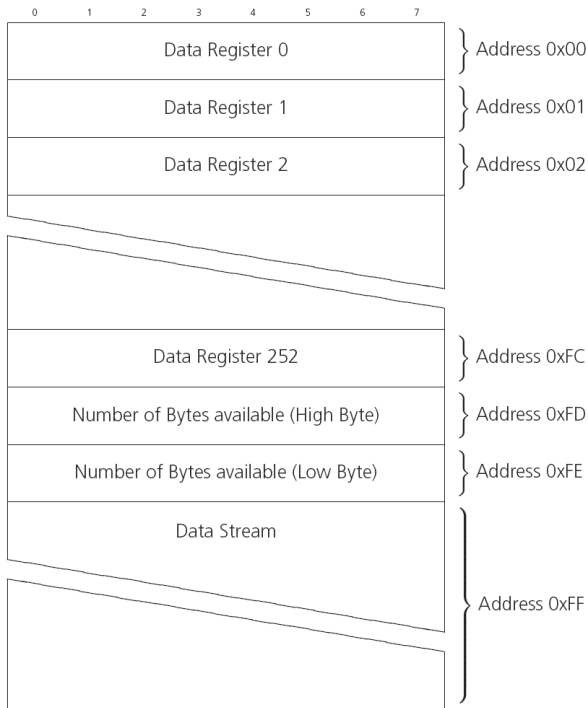

Figure 15: I2C register layout

3.6.2.2 Read access types

There are two I2C read transfer forms:

- The "random access" form: includes a slave register address and allows any register to be read.
- The "current address" form: omits the register address.

Figure 16 shows the format of the first one, the "random access" form of the request. Following the start condition from the master, the 7-bit device address and the RW bit (which is a logic low for write access) are clocked onto the bus by the master transmitter. The receiver answers with an acknowledge (logic low) to indicate that it recognizes the address.

Next, the 8-bit address of the register to be read must be written to the bus. Following the receiver's acknowledgment, the master again triggers a start condition and writes the device address, but this time the RW bit is a logic high to initiate the read access. Now, the master can read 1 to N bytes from the receiver, generating a not-acknowledge and a stop condition after the last byte being read.

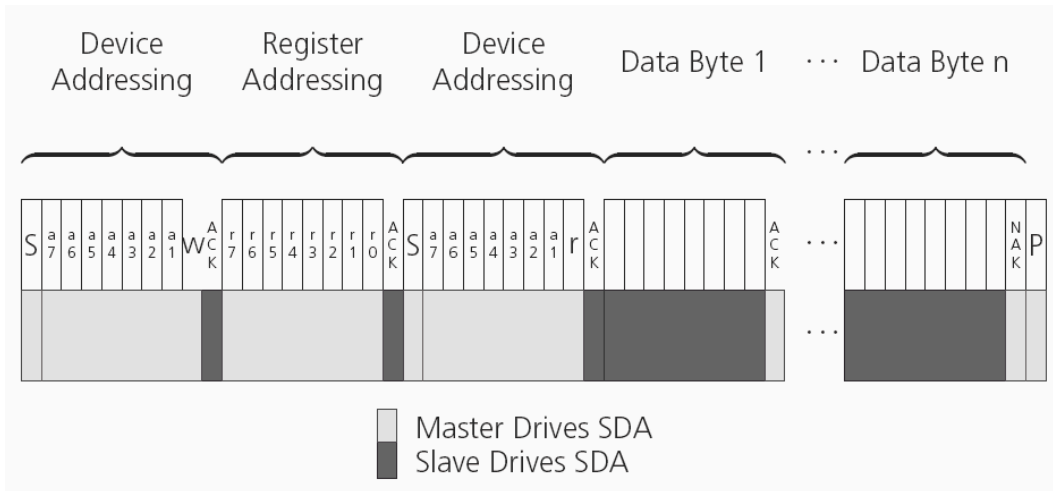

Figure 16: I2C random read access

If the second form, "current address" is used, an address pointer in the receiver is used to determine which register to read. This address pointer will increment after each read unless it is already pointing at register 0xFF, the highest addressable register, in which case it remains unaltered.

The initial value of this address pointer at start-up is 0xFF, so by default all current address reads will repeatedly read register 0xFF and receive the next byte of message data (or 0xFF if no message data is waiting).

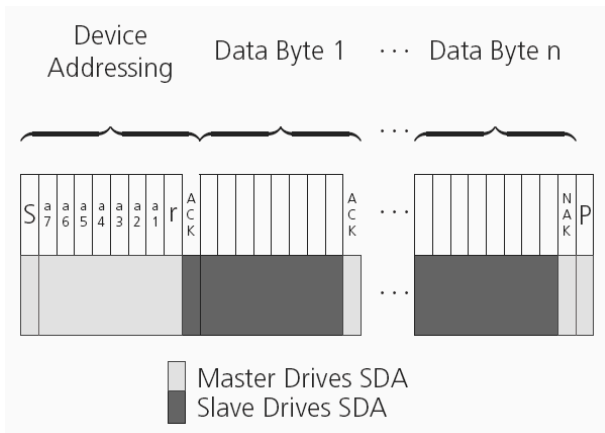

Figure 17: I2C current address read access

3.6.2.3 Write access

The receiver does not provide any write access except for writing UBX and NMEA messages to the receiver, such as configuration or aiding data. Therefore, the register set mentioned in the section [Read access](#) is not writable.

Following the start condition from the master, the 7-bit device address and the RW bit (which is a logic low for write access) are clocked onto the bus by the master transmitter. The receiver answers with an acknowledge (logic low) to indicate that it is responsible for the given address.

The master can write 2 to N bytes to the receiver, generating a stop condition after the last byte being written. The number of data bytes must be at least 2 to properly distinguish from the write access to set the address counter in random read accesses.

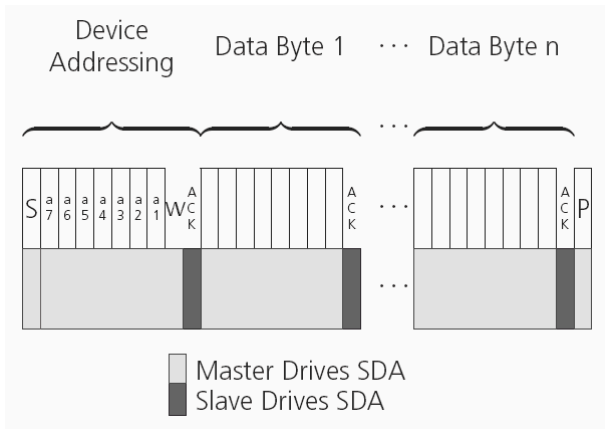

Figure 18: I2C write access

3.6.3 SPI interface

The ZED-F9P high precision receiver has an SPI slave interface that can be selected by setting `D_SEL = 0`. The SPI slave interface is shared with UART1 and I2C port, the physical pins are same. The SPI pins available are: `SPI_MISO (TXD)`, `SPI_MOSI (RXD)`, `SPI_CS_N` and `SPI_CLK`. See more info about communication interface selection from [D_SEL](#) section.

The SPI interface is designed to allow communication to a host CPU. The interface can be operated in slave mode only.

The maximum transfer rate using SPI is 150 kBytes/s and the maximum SPI clock frequency is 5.5 MHz.

3.6.3.1 Read access

As the register mode is not implemented for the SPI port, only the UBX/NMEA message stream is provided. This stream is accessed using the back-to-back read and write access (see section [Back-to-back read and write access](#) below). When no data is available to be written to the receiver, `MOSI` should be held logic high, i.e. all bytes written to the receiver are set to `0xFF`.

To prevent the receiver from being busy parsing incoming data, the parsing process is stopped after 50 subsequent bytes containing `0xFF`. The parsing process is re-enabled with the first byte not equal to `0xFF`.

If the receiver has no more data to send, it sets `MISO` to logic high, i.e. all bytes transmitted decode to `0xFF`. An efficient parser in the host will ignore all `0xFF` bytes which are not part of a message and will resume data processing as soon as the first byte not equal to `0xFF` is received.

3.6.3.2 Back-to-back read and write access

The receiver does not provide any write access except for writing UBX and NMEA messages to the receiver, such as configuration or aiding data. For every byte written to the receiver, a byte will simultaneously be read from the receiver. While the master writes to `MOSI`, at the same time it needs to read from `MISO`, as any pending data will be output by the receiver with this access. The data on `MISO` represents the results from a current address read, returning `0xFF` when no more data is available.

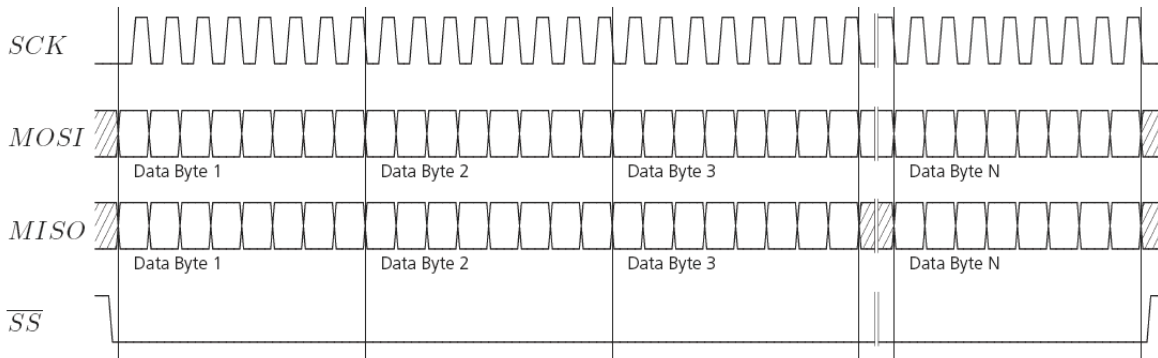







Figure 19: SPI back-to-back read/write access

3.6.4 USB interface

A single USB port is provided for host communication purposes.

The USB interface is compatible with a USB version 2.0 FS (full speed, 12 Mb/s) interface.

The ZED-F9P receiver supports only self-powered mode operation in which the receiver is supplied from its own power supply. The V_USB pin is used to detect the availability of the USB port, i.e. whether the receiver is connected to a USB host.

-  USB suspend mode is not supported.
-  USB bus-powered mode is not supported.
-  It is important to connect V_USB to ground and leave data lines open when the USB interface is not used in an application.
-  The voltage range for V_USB is specified from 3.0 V to 3.6 V, which differs slightly from the specification for VCC.
-  The boot screen is retransmitted on the USB port after enumeration. However, messages generated between boot-up of the receiver and USB enumeration are not visible on the USB port.

There are additional hardware requirements if USB is to be used:

- Pin 38, V_USB needs to be powered by a separate LDO enabled by module VCC and supplied by the USB host.
- A pull down resistor is required on the output of this V_USB LDO
- V_USB (pin 38) requires 1 uF capacitor mounted adjacent to the pin to ensure correct V_USB voltage detection
- Apply USB_DM and USB_DP series resistors; typically 27 Ω

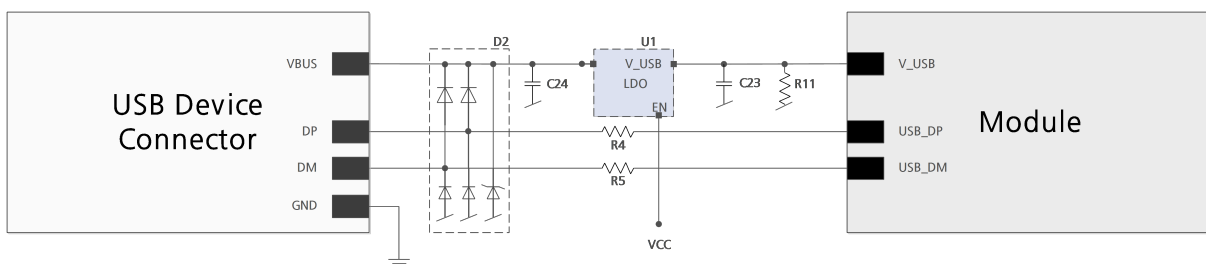

Figure 20: ZED-F9P example circuit for USB interface

R11 = 100 k Ω is recommended

R4, R5 = 27 Ω is recommended

3.7 Predefined PIOs

In addition to the communication ports, there are some predefined PIOs provided by ZED-F9P to interact with the receiver. These PIOs are described in this chapter.

3.7.1 D_SEL

The D_SEL pin can be used to configure the functionality of pins 42 to 45 . It is possible to configure the pins as UART1 + I2C, or as SPI. SPI is not available unless D_SEL pin is set to low. See [Table 23](#) below.

Pin No	D_SEL == 0	D_SEL == 1
42	SPI_MISO	UART1 TXD
43	SPI_MOSI	UART1 RXD
44	SPI_CS_N	I2C SDA
45	SPI_CLK	I2C SCL

Table 23: D_SEL configuration

3.7.2 RESET_N

The ZED-F9P provides the ability to reset the receiver. The RESET_N pin is an input-only pin with an internal pull-up resistor. Driving RESET_N low for at least 100 ms will trigger a cold start.



The RESET_N pin will delete all information and trigger a cold start. It should only be used as a recovery option.

3.7.3 SAFEBOOT_N

The ZED-F9P provides a SAFEBOOT_N pin that is used to command the receiver safe boot mode.

If this pin is low at power up, the receiver starts in safe boot mode and GNSS operation is disabled.

The safe boot mode can be used to recover from situations where the flash content has become corrupted and needs to be restored.

In safe boot mode the receiver runs from a passive oscillator circuit with less accurate timing and hence the receiver is unable to communicate via USB.

In this mode only UART1 and I2C communication is possible. For communication via UART1 in safe boot mode, the host must send a training sequence (0 x 55 55 at 9600 baud) to the receiver in order to begin communication. After this the host must wait at least 2 ms before sending any data.

It is recommended to have the possibility to pull the SAFEBOOT_N pin low in the application. This can be provided using an externally connected test point or a host I/O port.

3.7.4 TIMEPULSE

The ZED-F9P high precision receiver provides a time pulse on the TIMEPULSE pin.



More information about the Timepulse feature and its configuration can be found in the chapter [Time pulse](#)

3.7.5 TX_READY

This feature enables each port to define a corresponding pin, which indicates if bytes are ready to be transmitted. A listener can wait on the TX-READY signal instead of polling the I2C or SPI interfaces. The CFG-TXREADY message lets you configure the polarity and the number of bytes in the buffer before the TX-READY signal goes active. By default, this feature is disabled. For USB, this feature is configurable but might not behave as described below due to a different internal transmission mechanism. If the number of pending bytes reaches the threshold configured for this port, the corresponding pin will become active (configurable active-low or active-high), and stay active until the last bytes have been transferred from software to hardware.



This is not necessarily equal to all bytes transmitted, i.e. after the pin has become inactive, up to 16 bytes might still need to be transferred to the host.

The TX_READY pin can be selected from all PIOs which are not in use (see UBX-MON-HW3 in the ZED-F9P Interface Description [2] for a list of the PIOs and their mapping). Each TX_READY pin is exclusively associated to one port and cannot be shared. If PIO is invalid or already in use, only the configuration for the specific TX_READY pin is ignored, the rest of the port configuration is applied if valid. The acknowledge message does not indicate if the TX-READY configuration is successfully set, it only indicates the successful configuration of the port. To validate successful configuration of the TX_READY pin, the port configuration should be read back and the settings of TX-READY feature verified (will be set to disabled/all zero if the settings are invalid).

The threshold when TX_READY is asserted should not be set above 2 kB as it is possible that the internal message buffer limit is reached before this. This results in the TX_READY pin never being set as the messages are discarded before the threshold is reached.

3.7.5.1 Extended TX timeout

If the host does not communicate over SPI or I2C for more than approximately 2 seconds, the device assumes that the host is no longer using this interface and no more packets are scheduled for this port. This mechanism can be changed by enabling "extended TX timeouts", in which case the receiver delays idling the port until the allocated and undelivered bytes for this port reach 4 kB. This feature is especially useful when using the TX-READY feature with a message output rate of less than once per second, and polling data only when data is available, determined by the TX_READY pin becoming active.

3.7.6 EXTINT

EXTINT is an external interrupt pin with fixed input voltage thresholds with respect to VCC. It can be used for functions such as accurate external frequency aiding and on/off control. Leave open if unused, this function is disabled by default.

3.7.7 GEOFENCE_STAT interface

The ZED-F9P provides a GEOFENCE_STAT pin that indicates the current geofence status as to whether the receiver is inside any of the active areas.

This feature can be used for example to wake up a sleeping host when a defined geofence condition is reached. It is possible to configure up to four circular areas as geofence locations. Once configured, the receiver continuously compares its current position with the preset geofenced areas.

For more information in this functionality, see [Geofence state evaluation](#).

The receiver toggles the assigned pin according to the combined geofence state.

There are three possible outcomes for each geofence:

- *Inside* - The position is inside the geofence with the configured confidence level
- *Outside* - The position lies outside of the geofence with the configured confidence level
- *Unknown* - There is no valid position solution or the position uncertainty does not allow for unambiguous state evaluation

The GEOFENCE_STAT pin is always set to high level when the combine geofence state is unknown. The low level can either represent the inside state or the outside state according to the value set in the CFG-GEOFENCE-PINPOL configuration item. If the receiver is in software backup or in a reset, the pin will go to high accordingly.



The CFG-GEOFENCE-PIN configuration item refers to a PIO and not a physical device pin. The PIO number must be set so that it is mapped to the assigned geofence state device pin. The ZED-F9P high precision receiver is assigned PIO3 that is assigned to module pin 19.

3.7.8 RTK_STAT interface

The ZED-F9P provides an RTK_STAT pin that provides an indication of the RTK positioning status. It can be used to confirm if a valid stream of RTCM messages is being received. As valid RTCM messages we only consider the RTCM messages that are supported and used by the receiver.

In general, the RTK_STAT level can be interpreted as follows: Alternating (blinking) pin level, indicates that a valid stream of RTCM messages is being received and utilized but no RTK fixed mode has been achieved. An active low pin level indicates that RTK fixed mode has been achieved. Otherwise, the pin level is high.

The RTK_STAT pin status can be mapped to the `carrSoln` field of the UBX-NAV-PVT and interpreted as follows:

- An active low pin level indicates that RTK fixed mode has been achieved
- Alternating (blinking) pin level, indicates that a valid stream of RTCM messages is being received and utilized but no RTK fixed mode has been achieved
- An active high pin level indicates that no carrier phase solution is available

3.8 Antenna supervisor

An active antenna supervisor provides the means to check the antenna for open and short circuits and to shut off the antenna supply if a short circuit is detected. Once enabled, the active antenna supervisor produces status messages, reporting in NMEA and/or UBX protocol.

The antenna supervisor can be configured through the CFG-HW-ANT_* configuration items. The current configuration of the active antenna supervisor can also be checked by polling the related CFG-HW_ANT_* configuration items.

The current active antenna status can be determined by polling the UBX-MON-RF message. If an antenna is connected, the initial state after power-up is "Active Antenna OK" in the UBX-MON-RF message in the u-center "Message View".

An active antenna supervisor circuit is connected to the ANT_DET, ANT_OFF, ANT_SHORT_N pins. For an example the open circuit detection circuit using ANT_DET, "high" = Antenna detected (antenna consumes current); "low" = Antenna not detected (no current drawn).

The following schematic details the required circuit and the sections following it explain how to enable and monitor each feature:

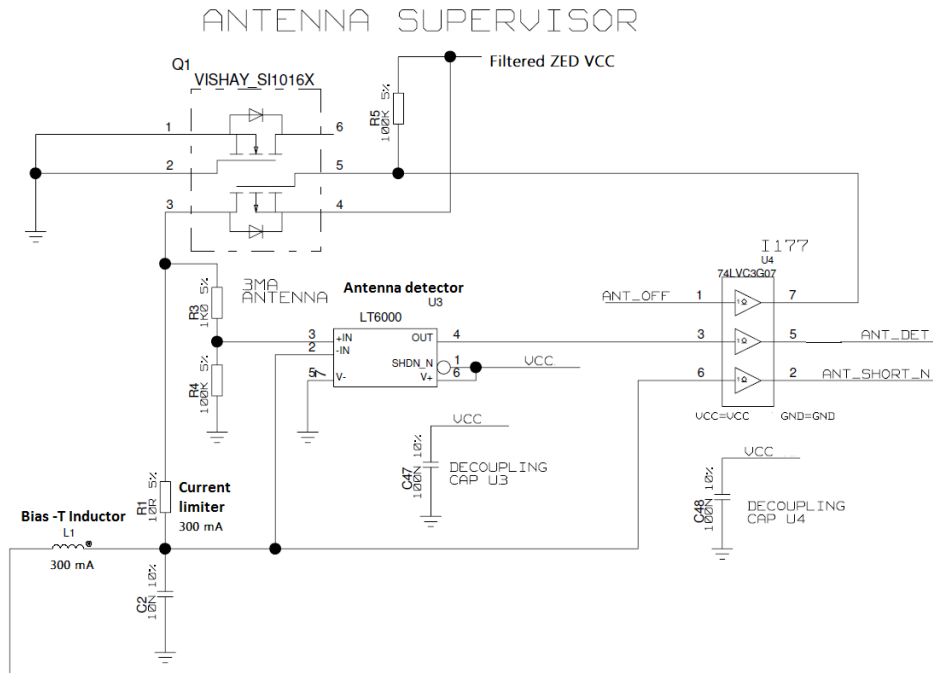
Figure 21: ZED-F9P antenna supervisor

- The bias-t inductor must be chosen for multi-band operation; a value of 120 nH 5% is required for our recommended Murata part if the current is limited below its 110 mA rating. See [Antenna bias](#) section for additional information.
- Circuit shows buffer [U4]. Buffer is not strictly necessary when supplied from VCC. It is only required when supplying antenna voltage that is not obtained from or controlled by module VCC or VCC_RF .

Part	Recommendation	Comment
L1		300mA and >500 Ω at L-band frequencies
C2	MURATA GRM033R71C103KE14	CAP CER X7R 0402 10N 10% 16V
	TYCO, 0.25PF, PESD0402-140 -55/+125C	ESD protection diode on RF trace

Table 24: Recommended components for antenna supervisor

3.8.1 Antenna voltage control - ANT_OFF

- Antenna status (as reported in UBX-MON-RF and UBX-INF-NOTICE messages) is not reported unless the antenna voltage control has been enabled.

Enable the antenna voltage control by setting the configuration item CFG-HW-ANT_CFG_VOLTCTRL to true (1).

Result:

- UBX-MON-RF in u-center "Message View": Antenna status = OK. Antenna power status = ON
- ANT_OFF pin = active high to turn antenna off therefore the pin is low to enable an external antenna.

Start-up message at power up if configuration stored:

```
$GNXTXT,01,01,02,ANTSUPERV=AC *00
```

```
$GNXTXT,01,01,02,ANTSTATUS=INIT*3B
```

```
$GNTXT,01,01,02,ANTSTATUS=OK*25
```

ANTSUPERV=AC indicates antenna control is activated

3.8.2 Antenna short detection - ANT_SHORT_N

Enable the antenna short detection by setting the configuration item CFG-HW-ANT_CFG_SHORTDET to true (1).

Result:

- UBX-MON-RF in u-center "Message View": Antenna status = OK. Antenna power status = ON
- ANT_OFF = active high to disable an external antenna therefore the pin is low to enable an external antenna.
- ANT_SHORT_N = active low to detect a short therefore the pin is high (PIO pull up enabled to be pulled low if shorted)

Start-up message at power up if configuration is stored:

```
$GNTXT,01,01,02,ANTSUPERV=AC SD *37
```

```
$GNTXT,01,01,02,ANTSTATUS=INIT*3B
```

```
$GNTXT,01,01,02,ANTSTATUS=OK*25
```

ANTSUPERV=AC SD (Antenna control and short detection activated)

Then if shorted (ANT_SHORT_N pulled low):

- UBX-MON-RF in u-center "Message View": Antenna status = SHORT. Antenna power status = ON (Antenna power control power down when short has not been enabled = off by default).

```
$GNTXT,01,01,02,ANTSTATUS=SHORT*73
```

- ANT_OFF = active high therefore still low (still enabled as auto power down is not enabled)



After a detected antenna short, the reported antenna status will keep on being reported as shorted. If the antenna short detection auto recovery is enabled, then the antenna status can recover after a timeout. To recover the antenna status immediately, a power cycle is required or configuring the antenna short detection functionality off and on.

3.8.3 Antenna short detection auto recovery

Enable the antenna short detection auto recovery by setting the configuration item CFG-HW-ANT_CFG_RECOVER to true (1).

Result:

- UBX-MON-RF in u-center "Message View": Antenna status = OK. Antenna power status = ON
- ANT_OFF = active high there for the PIO is low to enable an external antenna
- ANT_SHORT_N = high (PIO pull up enabled to be pulled low if shorted)

Start-up message at power up if configuration is stored:

```
$GNTXT,01,01,02,ANTSUPERV=AC SD PDoS SR*3E
```

```
$GNTXT,01,01,02,ANTSTATUS=INIT*3B
```

```
$GNTXT,01,01,02,ANTSTATUS=OK*25
```

ANTSUPERV=AC SD PDoS SR (indicates short circuit recovery added - SR)

Then if antenna is shorted (ANT_SHORT_N pulled low):

- \$GNTXT, 01, 01, 02, ANTSTATUS=SHORT*73
- UBX-MON-RF in u-center "Message View": Antenna status = SHORT. Antenna power status = OFF
- ANT_OFF = high (to disable - active high)

After a time out period receiver will re-test the short condition by enabling ANT_OFF = LOW

If a short is not present it will report antenna condition is OK:

```
$GNTXT, 01, 01, 02, ANTSTATUS=OK*25
```

UBX-MON-RF in u-center "Message View": Antenna status = OK. Antenna power status = ON

3.8.4 Antenna open circuit detection - ANT_DETECT

Enable the antenna open circuit detection by setting the configuration item CFG-HW-ANT_CFG_OPENDET to true (1).

Result:

- UBX-MON-RF in u-center "Message View": Antenna status = OK. Antenna power status = ON
- ANT_OFF = active high therefore PIO is low to enable external antenna
- ANT_SHORT_N = active low therefore PIO is high (PIO pull up enabled to be pulled low if shorted)
- ANT_DETECT = active high therefore PIO is high (PIO pull up enabled to be pulled low if antenna not detected)

Start-up message at power up if configuration is stored:

```
$GNTXT, 01, 01, 02, ANTSUPERV=AC SD OD PDoS SR*15
```

```
$GNTXT, 01, 01, 02, ANTSTATUS=INIT*3B
```

```
$GNTXT, 01, 01, 02, ANTSTATUS=OK*25
```

ANTSUPERV=AC SD OD PDoS SR (indicates open circuit detection added - OD)

Then if ANT_DETECT is pulled low to indicate no antenna:

```
$GNTXT, 01, 01, 02, ANTSTATUS=OPEN*35
```

Then if ANT_DETECT is left floating or it is pulled high to indicate antenna connected:

```
$GNTXT, 01, 01, 02, ANTSTATUS=OK*25
```

3.9 Multiple GNSS assistance (MGA)

The u-blox MGA services provide a proprietary implementation of an A-GNSS protocol compatible with u-blox GNSS receivers. When a client device makes an MGA request, the service responds with the requested data using UBX protocol messages. These messages are ready for direct transmission to the receiver communication port without requiring any modification by the MGA client.

Currently, these MGA services consist of AssistNow Online and Offline, each delivered by the HTTP or HTTPS protocols.

AssistNow Online optionally provides satellite ephemerides, health information and time aiding data suitable for GNSS receiver systems with direct internet access.

The AssistNow Offline service benefits u-blox GNSS receivers that only have occasional internet access. Users request data from the service by specifying the time period for which they want coverage (1 to 5 weeks).

The data downloaded from the service is organized by date and encoded into a sequence of UBX MGA messages.

The ZED-F9P supports AssistNow Online only.

3.9.1 Authorization

The AssistNow Online Service is only available for use by u-blox customers. In order to use the services, customers will need to obtain an authorization token from u-blox. This token must be supplied as a parameter whenever a request is made to either service. Please contact your local technical support or go to <https://www.u-blox.com/en/solution/services/assistnow> to get more information and request an authorization token.

3.9.2 Multiple servers

The implementation of the AssistNow Online Service is designed to be highly available and reliable. Nonetheless, there will be rare occasions when a server is not available (e.g. due to failure or some form of maintenance activity). In order to protect customers against the impact of such outages, u-blox runs at least two instances of the AssistNow Online Service on independent machines. Customers have a choice of requesting assistance data from any of these servers, as all will provide the same information. However, should one fail for whatever reason, it is highly unlikely that the other server(s) will also be unavailable. Therefore customers requiring the best possible availability are recommended to implement a scheme where they direct their requests to a chosen server, but, if that server fails to respond, have a fallback mechanism to use another server instead.

3.9.3 Preserving information during power-off

The performance of u-blox receivers immediately after they are turned on is enhanced by providing them with as much useful information as possible. AssistNow services are one way to achieve this, but retaining information from previous use of the receiver can be just as valuable. All the types of data delivered by assistance can be retained while the receiver is powered down for use when power is restored. Obviously the value of this data will diminish as time passes, but in many cases it remains very useful and can significantly improve time to first fix.

There are several ways in which a u-blox receiver can retain useful data while it is powered down, including:

- **Battery-backed RAM:** The receiver can be supplied with sufficient power to maintain a small portion of internal storage, while it is otherwise turned off. This is the best mechanism, provided that the small amount of electrical power required can be supplied continuously. V_BCKP is the pin to sustain battery-backed RAM.
- **Save-on-Shutdown:** The receiver can be instructed to dump its current state to flash memory as part of the shutdown procedure; this data is then automatically retrieved when the receiver is restarted. For more information, see the description of the UBX-UPD-SOS messages in the ZED-F9P Interface description [2].

3.9.4 AssistNow Online

AssistNow Online is u-blox's end-to-end Assisted GNSS (A-GNSS) solution for receivers that have access to the internet. Data supplied by the AssistNow Online Service can be directly uploaded to a u-blox receiver in order to substantially reduce time to first fix (TTFF), even under poor signal conditions (typically around 2 seconds; see ZED-F9P Data sheet [1] "Aided start"). The system

works by collecting data such as ephemeris and almanac from the satellites through u-blox's "Global Reference Network" of receivers and providing this data to customers in a convenient form that can be forwarded directly to u-blox receivers.

The AssistNow Online Service uses a simple, stateless, HTTP interface. Therefore, it works on all standard mobile communication networks that support internet access, including GPRS, UMTS and Wireless LAN. No special arrangements need to be made with mobile network operators to enable AssistNow Online.

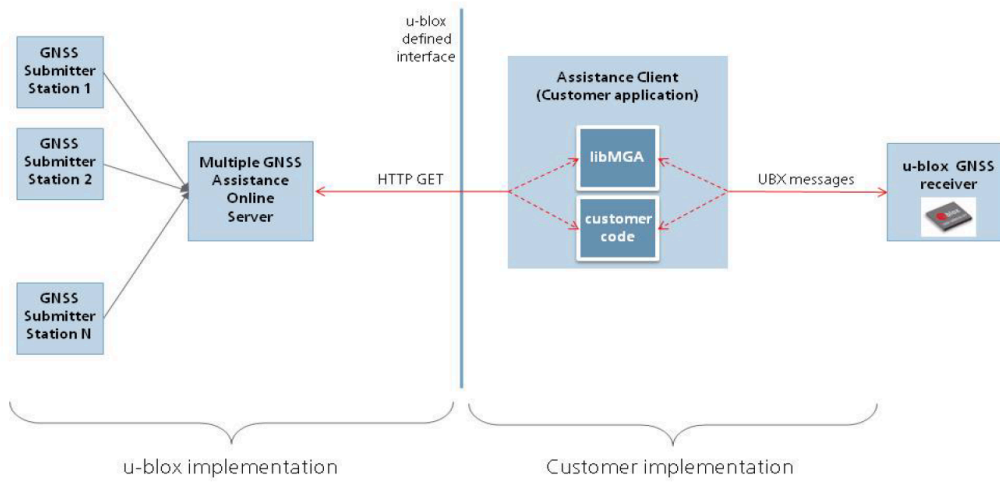

Figure 22: MGA architecture

The data returned by the AssistNow Online Service is a sequence of UBXMGA messages, starting with an estimate of the current time in the form of a UBXMGA-INITIME_UTC message.

- AssistNow Online currently supports GPS, GLONASS, BeiDou, Galileo, and QZSS.
- Customers may choose to use third party sources of assistance data instead of using the AssistNow Online Service. Customers choosing this option will need to ensure that the data is converted from the format used by the third party source to the appropriate MGA messages. However, it is important to ensure that the receiver has an estimate of the current time before it processes any other assistance data. For this reason, it is strongly recommended to send a UBXMGA-INITIME_UTC or UBXMGA-INITIME_GNSS as the first message of any assistance.

3.9.4.1 Host software

As u-blox receivers have no means to connect directly with the internet, the AssistNow Online system can only work if the host system that contains the receiver can connect to the internet, download the data from the AssistNow Online Service and forward it on to the receiver. In the simplest case that may involve fetching the data from the AssistNow Online Service (by means of a single HTTP or HTTPS GET request), and sending the resulting data to the receiver.

Depending on the circumstances, it may be beneficial for the host software to include:

- Creating an appropriate UBXMGA-INITIME_UTC message to deliver a better estimation of the current time to the receiver, especially if the host system has a very good estimation of the current time and can deliver a time pulse to one of the receiver's EXTINT pins.
- Enabling and using flow control to prevent loss of data due to buffer overflow in the receiver.



u-blox provides the source code for an example library, called libMGA, that provides all of the functionality we expect in most host software.

3.9.4.2 AssistNow Online sequence

A typical sequence of use of the AssistNow Online Service comprises the following steps:

- Power up the u-blox receiver.
- Request data from the AssistNow Online Service.
- Optionally send UBX-MGA-INI-TIME_UTC followed by hardware time synchronization pulse.
- Send the UBX messages obtained from the AssistNow Online Service to the receiver.

3.9.4.3 Flow control

u-blox receivers aim to process incoming messages as quickly as possible, but there will always be a small delay in processing each message. Uploading assistance data to the receiver can involve sending as many as one hundred individual messages to the receiver, one after the other. If the communication link is fast, and/or the receiver is busy (trying to acquire new signals), it is possible that the internal buffers will overflow and some messages will be lost. In order to combat this, u-blox receivers support an optional flow control mechanism for assistance.

Flow control is activated by setting the CFG-NAVSPG-ACKAIDING configuration item. As a result the receiver will issue an acknowledgment message (UBX-ACK-ACK) for each assistance message it successfully receives. The host software can examine these acknowledgments to establish whether there were any problems with the data sent to the receiver and deduce (by the lack of acknowledgment) if any messages have been lost. It may then be appropriate to resend some of the assistance messages.

The simplest way to implement flow control would be to send one UBX-MGA message at a time, waiting for the acknowledgment, before sending the next. However, such a strategy is likely to introduce significant delays into the whole assistance process. The best strategy will depend on the amount of assistance data being sent and the nature of the communications link (e.g. baud rate of serial link). u-blox recommends that when customers are developing their host software they start by sending all assistance messages and then analyze the resulting acknowledgments to see if any messages have been lost. Adding small delays during the transmission may be a simple but effective way to avoid loss of data.

3.9.4.4 Service parameters

The information exchange with the AssistNow Online Service is based on the HTTP protocol. The u-blox MGA service supports encrypted HTTPS communication. Upon reception of an HTTP GET request, the server will respond with the required messages in binary format or with an error string in text format. After delivery of all data, the server will terminate the connection.

The HTTP GET request from the client to the server should contain a standard HTTP query string in the request URL. The query string consists of a set of "key=value" parameters in the following form:

key=value;key=value;key=value;

The following rules apply:

- The order of keys is important.
- Keys and values are case-sensitive.
- Keys and values must be separated by an "equal" character ("=").
- Key/value pairs must be separated by semicolons (";").
- If a value contains a list, each item in the list must be separated by a comma (",").

The following table describes the keys that are supported:

Key name	Unit/range	Optional	Description
token	String	Mandatory	The authorization token supplied by u-blox when a client registers to use the service.
gnss	String	Mandatory	A comma-separated list of the GNSS for which data should be returned. Valid GNSS are: gps, gal, glo, bds and qzss (case-sensitive).
datatype	String	Mandatory	A comma-separated list of the data types required by the client. Valid data types are: eph, alm, aux and pos. Time data is always returned for each request. If the value of this parameter is an empty string, only time data will be returned.
lat	Numeric [degrees]	Optional	Approximate user latitude in WGS 84 expressed in degrees and fractional degrees. Must be in range -90 to 90. Example: lat=47.2.
lon	Numeric [degrees]	Optional	Approximate user longitude in WGS 84 expressed in degrees and fractional degrees. Must be in range -180 to 180. Example: lon=8.55.
alt	Numeric [meters]	Optional	Approximate user altitude above WGS 84 Ellipsoid. If this value is not provided, the server assumes an altitude of 0 meters. Must be in range -1000 to 50000.
pacc	Numeric [meters]	Optional	Approximate accuracy of submitted position (see the Position parameters (lat, lon, alt and pacc) section below). If this value is not provided, the server assumes an accuracy of 300 km. Must be in range 0 to 6000000.
tacc	Numeric [seconds]	Optional	The timing accuracy (see the Time parameters (tacc and latency) section below). If this value is not provided, the server assumes an accuracy of 10 seconds. Must be in range 0 to 3600.
latency	Numeric [seconds]	Optional	Typical latency between the time the server receives the request, and the time when the assistance data arrives at the u-blox receiver. The server can use this value to correct the time being transmitted to the client. If this value is not provided, the server assumes a latency of 0. Must be in range 0 to 3600.
filteronpos	(no value required)	Optional	If present, the ephemeris data returned to the client will only contain data for the satellites which are likely to be visible from the approximate position provided by the lat, lon, alt and pacc parameters. If the lat and lon parameters are not provided the service will return an error.
filteronsv	String	Optional	A comma-separated list of u-blox gnssid:svId pairs. The ephemeris data returned to the client will only contain data for the listed satellites.

Table 25: AssistNow Online parameter keys

Thus, as an example, a valid parameter string would be:

```
token=XXXXXXXXXXXXXXXXXXXXXXXXX;gnss=gps,qzss;datatype=eph,pos,aux;lat=47.28;lon=8.56;pacc=1000
```

3.9.4.4.1 Position parameters (lat, lon, alt and pacc)

The position parameters (lat, lon, alt and pacc) are used by the server for two purposes:

- If the filteronpos parameter is provided, the server determines the currently visible satellites at the user position, and only sends the ephemeris data of those satellites which should be in view at the location of the user. This reduces bandwidth requirements. In this case the "pacc" value is taken into account, meaning that the server will return all SVs visible in the given uncertainty region.
- If the datatype "pos" is requested, the server will return the position and accuracy in the response data. When this data is supplied to the u-blox receiver, depending on the accuracy of the provided data, the receiver can then choose to select a better startup strategy. For example, if the position is accurate to 100 km or better, the u-blox receiver will choose to go for a more optimistic startup strategy. This will result in quicker startup time. The receiver will decide which strategy to choose, depending on the "pacc" parameter. If the submitted user position is less accurate than what is being specified with the "pacc" parameter, then the user will experience prolonged or even failed startups.

3.9.4.4.2 Time parameters (tacc and latency)

Time data is always returned with each request. The time data refers to the time at which the response leaves the server, corrected by an optional latency value. This time data provided by the service is accurate to approximately 10 ms but by default the time accuracy is indicated to be +/-10

seconds in order to account for network latency and any time between the client receiving the data and it being provided to the receiver.

If both the network latency and the client latency can safely be assumed to be very low (or are known), the client can choose to set the accuracy of the time message (`tacc`) to a much smaller value (e.g. 0.5 s). This will result in a faster TTFF. The latency can also be adjusted as needed. However, these fields should be used with caution: if the time accuracy is not correct when the time data reaches the receiver, the receiver may experience prolonged or even failed startups.

For optimal results, the client should establish an accurate sense of time itself (e.g. by calibrating its system clock using a local NTP service) and then modify the time data received from the service as appropriate.

3.10 Clocks and time

This section introduces and explains the concepts of receiver clocks and time bases.

3.10.1 Receiver local time

The receiver is dependent on a local oscillator for both the operation of its radio parts and also for timing within its signal processing. No matter what nominal frequency the local oscillator has, u-blox receivers subdivide the oscillator signal to provide a 1 kHz reference clock signal, which is used to drive many of the receiver's processes. In particular, the measurement of satellite signals is arranged to be synchronized with the "ticking" of this 1 kHz clock signal.

When the receiver first starts, it has no information about how these clock ticks relate to other time systems; it can only count time in 1 millisecond steps. However, as the receiver derives information from the satellites it is tracking or from aiding messages, it estimates the time that each 1 kHz clock tick takes in the time-base of one of the GNSS systems in a multi-GNSS receiver. In previous generations of u-blox receivers this was always the GPS time-base, but for the current generation it could be GPS, GLONASS, Galileo, or BeiDou. This estimate of GNSS time based on the local 1 kHz clock is called receiver local time.

As receiver local time is a mapping of the local 1 kHz reference onto a GNSS time-base, it may experience occasional discontinuities, especially when the receiver first starts up and the information it has about the time-base is changing. Indeed, after a cold start, the receiver local time will initially indicate the length of time that the receiver has been running. However, when the receiver obtains some credible timing information from a satellite or an aiding message, it will jump to an estimate of GNSS time.

3.10.2 Navigation epochs

Each navigation solution is triggered by the tick of the 1 kHz clock nearest to the desired navigation solution time. This tick is referred to as a navigation epoch. If the navigation solution attempt is successful, one of the results is an accurate measurement of time in the time-base of the chosen GNSS system, called GNSS system time. The difference between the calculated GNSS system time and receiver local time is called the clock bias (and the clock drift is the rate at which this bias is changing).

In practice the receiver's local oscillator will not be as stable as the atomic clocks to which GNSS systems are referenced and consequently clock bias will tend to accumulate. However, when selecting the next navigation epoch, the receiver will always try to use the 1 kHz clock tick which it estimates to be closest to the desired fix period as measured in GNSS system time. Consequently the number of 1 kHz clock ticks between fixes will occasionally vary. This means that when producing

one fix per second, there will normally be 1000 clock ticks between fixes, but sometimes, to correct drift away from GNSS system time, there will be 999 or 1001.

The GNSS system time calculated in the navigation solution is always converted to a time in both the GPS and UTC time-bases for output.

Clearly when the receiver has chosen to use the GPS time-base for its GNSS system time, conversion to GPS time requires no work at all, but conversion to UTC requires knowledge of the number of leap seconds since GPS time started (and other minor correction terms). The relevant GPS-to-UTC conversion parameters are transmitted periodically (every 12.5 minutes) by GPS satellites, but can also be supplied to the receiver via the UBX-MGA-GPS-UTC aiding message. By contrast when the receiver has chosen to use the GLONASS time-base as its GNSS system time, conversion to GPS time is more difficult as it requires knowledge of the difference between the two time-bases, but as GLONASS time is closely linked to UTC, conversion to UTC is easier.

When insufficient information is available for the receiver to perform any of these time-base conversions precisely, pre-defined default offsets are used. Consequently plausible times are nearly always generated, but they may be wrong by a few seconds (especially shortly after receiver start). Depending on the configuration of the receiver, such "invalid" times may well be output, but with flags indicating their state (e.g. the "valid" flags in UBX-NAV-PVT).



u-blox receivers employ multiple GNSS system times and/or receiver local times (in order to support multiple GNSS systems concurrently), so users should not use UBX messages reporting GNSS system time or receiver local time. It is recommended to use messages that report UTC time and other messages are retained only for backwards compatibility reasons.

3.10.3 iTOW timestamps

All the main UBX-NAV messages (and some other messages) contain an iTOW field which indicates the GPS time at which the navigation epoch occurred. Messages with the same iTOW value can be assumed to have come from the same navigation solution.

Note that iTOW values may not be valid (i.e. they may have been generated with insufficient conversion data) and therefore it is not recommended to use the iTOW field for any other purpose.



The original designers of GPS chose to express time/date as an integer week number (starting with the first full week in January 1980) and a time of week (often abbreviated to TOW) expressed in seconds. Manipulating time/date in this form is far easier for digital systems than the more conventional year/month/day, hour/minute/second representation. Consequently, most GNSS receivers use this representation internally, only converting to a more conventional form at external interfaces. The iTOW field is the most obvious externally visible consequence of this internal representation.

If reliable absolute time information is required, users are recommended to use the UBX-NAV-PVT navigation solution message which also contains additional fields that indicate the validity (and accuracy in UBX-NAV-PVT) of the calculated times (see also the [GNSS times](#) section below for further messages containing time information).

3.10.4 GNSS times

Each GNSS has its own time reference for which detailed and reliable information is provided in the messages listed in the table below.

Time reference	Message
GPS time	UBX-NAV-TIMEGPS
BeiDou time	UBX-NAV-TIMEBDS

Time reference	Message
GLONASS time	UBX-NAV-TIMEGLO
Galileo time	UBX-NAV-TIMEGAL
UTC time	UBX-NAV-TIMEUTC

Table 26: GNSS times

3.10.5 Time validity

Information about the validity of the time solution is given in the following form:

- **Time validity:** Information about time validity is provided in the `valid` flags (e.g. `validDate` and `validTime` flags in the UBX-NAV-PVT message). If these flags are set, the time is known and considered valid for use. These flags are shown in table GNSS times in section GNSS times above as well as in the UBX-NAV-PVT message.
- **Time validity confirmation:** Information about confirmed validity is provided in the `confirmedDate` and `confirmedTime` flags in the UBX-NAV-PVT message. If these flags are set, the time validity can be confirmed by using an additional independent source, meaning that the probability of the time to be correct is very high. Note that information about time validity confirmation is only available if the `confirmedAvai` bit in the UBX-NAV-PVT message is set.



`validDate` means that the receiver has knowledge of the current date. However, it must be noted that this date might be wrong for various reasons. Only when the `confirmedDate` flag is set, the probability of the incorrect date information drops significantly.



`validTime` means that the receiver has knowledge of the current time. However, it must be noted that this time might be wrong for various reasons. Only when the `confirmedTime` flag is set, the probability of incorrect time information drops significantly.



`fullyResolved` means that the UTC time is known without full seconds ambiguity. When deriving UTC time from GNSS time the number of leap seconds must be known, with the exception of GLONASS. It might take several minutes to obtain such information from the GNSS payload. When the one second ambiguity has not been resolved, the time accuracy is usually in the range of ~20s.

3.10.6 UTC representation

UTC time is used in many NMEA and UBX messages. In NMEA messages it is always reported rounded to the nearest hundredth of a second. Consequently, it is normally reported with two decimal places (e.g. 124923.52). Although compatibility mode (selected using CFG-NMEA-COMPAT) requires three decimal places, rounding to the nearest hundredth of a second remains, so the extra digit is always 0.

UTC time is also reported within some UBX messages, such as UBX-NAV-TIMEUTC and UBX-NAV-PVT. In these messages date and time are separated into seven distinct integer fields. Six of these (year, month, day, hour, min and sec) have fairly obvious meanings and are all guaranteed to match the corresponding values in NMEA messages generated by the same navigation epoch. This facilitates simple synchronization between associated UBX and NMEA messages.

The seventh field is called nano and it contains the number of nanoseconds by which the rest of the time and date fields need to be corrected to get the precise time. So, for example, the UTC time 12:49:23.521 would be reported as: hour: 12, min: 49, sec: 23, nano: 521000000.

It is however important to note that the first six fields are the result of rounding to the nearest hundredth of a second. Consequently the nano value can range from -5000000 (i.e. -5 ms) to +994999999 (i.e. nearly 995 ms).

When the nano field is negative, the number of seconds (and maybe minutes, hours, days, months or even years) will have been rounded up. Therefore, some or all of them must be adjusted in order to get the correct time and date. Thus in an extreme example, the UTC time 23:59:59.9993 on 31st December 2011 would be reported as: year: 2012, month: 1, day: 1, hour: 0, min: 0, sec: 0, nano: -700000.

Of course, if a resolution of one hundredth of a second is adequate, negative nano values can simply be rounded up to 0 and effectively ignored.

Which master clock the UTC time is referenced to is output in the message UBX-NAV-TIMEUTC.

The preferred variant of UTC time can be specified using CFG-NAVSPG-UTCSTANDARD configuration item.

3.10.7 Leap seconds

Occasionally it is decided (by one of the international time keeping bodies) that, due to the slightly uneven spin rate of the Earth, UTC has moved sufficiently out of alignment with mean solar time (i.e. the Sun no longer appears directly overhead at 0 longitude at midday). A "leap second" is therefore announced to bring UTC back into close alignment. This normally involves adding an extra second to the last minute of the year, but it can also happen on 30th June. When this happens UTC clocks are expected to go from 23:59:59 to 23:59:60 and only then on to 00:00:00.

It is also theoretically possible to have a negative leap second, in which case there will only be 59 seconds in a minute and 23:59:58 will be followed by 00:00:00.

u-blox receivers are designed to handle leap seconds in their UTC output and consequently users processing UTC times from either NMEA or UBX messages should be prepared to handle minutes that are either 59 or 61 seconds long.

Leap second information can be polled from the u-blox receiver with the message UBX-NAV-TIMELS.

3.10.8 Real time clock

u-blox receivers contain circuitry to support a real time clock, which (if correctly fitted and powered) keeps time while the receiver is otherwise powered off. When the receiver powers up, it attempts to use the real time clock to initialize receiver local time and in most cases this leads to appreciably faster first fixes.

3.10.9 Date

All GNSS frequently transmit information about the current time within their data message. In most cases, this is a time of week (often abbreviated to TOW), which indicates the elapsed number of seconds since the start of the week (midnight Saturday/Sunday). In order to map this to a full date, it is necessary to know the week and so the GNSS also transmit a week number, typically every 30 seconds. Unfortunately the GPS L1C/A data message was designed in a way that only allows the bottom 10 bits of the week number to be transmitted. This is not sufficient to yield a completely unambiguous date as every 1024 weeks (a bit less than 20 years), the transmitted week number value "rolls over" back to zero. Consequently, GPS L1 receivers cannot tell the difference between, for example, 1980, 1999 or 2019 etc.

Fortunately, although BeiDou and Galileo have similar representations of time, they transmit sufficient bits for the week number to be unambiguous for the foreseeable future (the first ambiguity will be in 2078 for Galileo and not until 2163 for BeiDou). GLONASS has a different structure, based on a time of day, but again transmits sufficient information to avoid any ambiguity during the expected lifetime of the system (the first ambiguous date will be in 2124). Therefore, u-

blox 9 receivers using Protocol Version 24 and above regard the date information transmitted by GLONASS, BeiDou and Galileo to be unambiguous and, where necessary, use this to resolve any ambiguity in the GPS date.



Customers attaching u-blox receivers to simulators should be aware that GPS time is referenced to 6th January 1980, GLONASS to 1st January 1996, Galileo to 22nd August 1999 and BeiDou to 1st January 2006; the receiver cannot be expected to work reliably with signals simulated before these dates.

3.10.9.1 GPS-only date resolution

In circumstances where only GPS L1C/A signals are available and for receivers with earlier firmware versions, the receiver establishes the date by assuming that all week numbers must be at least as large as a reference rollover week number. This reference rollover week number is hard-coded at compile time and is normally set a few weeks before the software is completed, but it can be overridden by CFG-NAVSPG-WKNROLLOVER configuration item to any value the user wishes.

The following example illustrates how this works: Assume that the reference rollover week number set in the firmware at compile time is 1524 (which corresponds to a week in calendar year 2009, but would be transmitted by the satellites as 500). In this case, if the receiver sees transmissions containing week numbers in the range of 500 ... 1023, these will be interpreted as week numbers 1524 ... 2047 (calendar year 2009 ... 2019), whereas transmissions with week numbers from 0 to 499 are interpreted as week numbers 2048 ... 2547 (calendar year 2019 ... 2028).



It is important to set the reference rollover week number appropriately when supplying u-blox receivers with simulated signals, especially when the scenarios are in the past.

3.11 Timing functionality

In addition to positioning and navigation applications, GNSS signals are widely used as low-cost precision time or frequency references used by remote or distributed wireless communication, industrial, financial, and power distribution equipment. By capitalizing on atomic clocks which are on-board positioning satellites, GNSS signals which contain embedded timing information can be used to synchronize equipment, as well as to provide UTC time. For wireless communication standards that utilize Time Division Multiplex (TDM) and applications such as femtocell base stations, a precision time reference is mandatory.

3.11.1 Time pulse

3.11.1.1 Introduction

u-blox receivers include a time pulse function providing clock pulses with configurable duration and frequency. The time pulse function can be configured using the CFG-TP-* configuration group. The UBX-TIM-TP message provides time information for the next pulse and the time source.

Pulse Mode: Rising

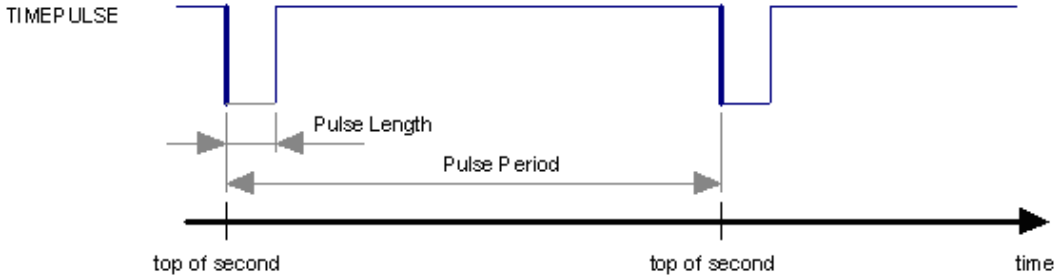
Pulse Mode: Falling

Figure 23: Time pulse
3.11.1.2 Recommendations

- The time pulse can be aligned to a wide variety of GNSS times or to variants of UTC derived from them (see the chapter on [time bases](#)). However, it is strongly recommended that the choice of time base is aligned with the available GNSS signals (so to produce GPS time or UTC(USNO), ensure GPS signals are available, and for GLONASS time or UTC(SU) ensure the presence GLONASS signals). This will involve coordinating the setting of CFG-SIGNAL-* configuration group with the choice of time pulse time base.
- When using time pulse for precision timing applications it is recommended to calibrate the antenna cable delay against a reference timing source.
- In order to get the best timing accuracy with the antenna, a fixed and *accurate* position is needed.
- If relative time accuracy between multiple receivers is required, do not mix receivers of different product families. If this is required, the receivers must be calibrated accordingly, by setting cable delay and user delay.
- The recommended configuration when using the UBX-TIM-TP message is to set both the measurement rate (CFG-RATE-MEAS) and the time pulse frequency (CFG-TP-*) to 1 Hz.



Since the rate of UBX-TIM-TP is bound to 1 Hz, more than one UBX-TIM-TP message can appear between two pulses if the time pulse frequency is set larger than 1 Hz. In this case all UBX-TIM-TP messages in between a time pulse T1 and T2 belong to T2 and the last UBX-TIM-TP before T2 reports the most accurate quantization error. In general, if the time pulse rate is not configured to 1 Hz, there will not be a single UBX-TIM-TP message for each time pulse.

The sequential order of the signal present at the TIMEPULSE pin and the respective output message for the simple case of 1 pulse per second (1PPS) is shown in the following figure.

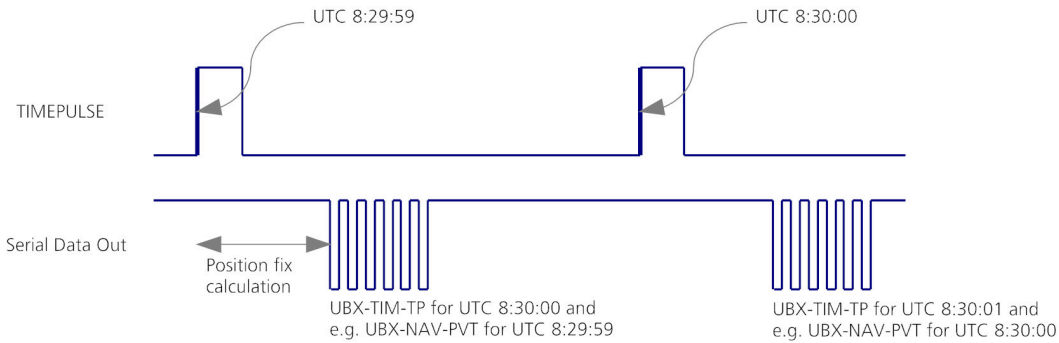

Figure 24: Time pulse and TIM-TP

3.11.1.3 GNSS time bases

GNSS receivers must handle a variety of different time bases as each GNSS has its own reference system time. What is more, although each GNSS provides a model for converting their system time into UTC, they all support a slightly different variant of UTC. So, for example, GPS supports a variant of UTC as defined by the US National Observatory, while BeiDou uses UTC from the National Time Service Center, China (NTSC). While the different UTC variants are normally closely aligned, they can differ by as much as a few hundreds of nanoseconds.

Although u-blox receivers can combine a variety of different GNSS times internally, the user must choose a single type of GNSS time and, separately, a single type of UTC for input (on EXTINTs) and output (via the time pulse) and the parameters reported in corresponding messages.

The CFG-TP-* configuration group allows the user to choose between any of the supported GNSS (GPS, GLONASS, BeiDou, etc) times and UTC. Also, the CFG-NAVSPG-* configuration group allows the user to select which variant of UTC the receiver should use. This includes an "automatic" option which causes the receiver to select an appropriate UTC version itself, based on the GNSS configuration, using, in order of preference, USNO if GPS is enabled, SU if GLONASS is enabled, NTSC if BeiDou is enabled and, finally, European if Galileo is enabled.

The receiver will assume that the input time pulse uses the same GNSS time base as specified for the output using CFG-TP-*. So if the user selects GLONASS time for time pulse output, any time pulse input must also be aligned to GLONASS time (or to the separately chosen variant of UTC). Where UTC is selected for time pulse output, any GNSS time pulse input will be assumed to be aligned to GPS time.



u-blox receivers allow users to independently choose GNSS signals used in the receiver (using CFG-SIGNAL-*) and the input/output time base (using CFG-TP-*). For example it is possible to instruct the receiver to use GPS and GLONASS satellite signals to generate BeiDou time. This practice will compromise time-pulse accuracy if the receiver cannot measure the timing difference between the constellations directly and is therefore not recommended.



The information that allows GNSS times to be converted to the associated UTC times is only transmitted by the GNSS at relatively infrequent periods. For example GPS transmits UTC(USNO) information only once every 12.5 minutes. Therefore, if a time pulse is configured to use a variant of UTC time, after a cold start, substantial delays before the receiver has sufficient information to start outputting the time pulse can be expected.

3.11.1.4 Time pulse configuration

u-blox ZED-F9P receivers provide a time pulse (TIMEPULSE) signal with a configurable pulse period, pulse length and polarity (rising or falling edge).

It is possible to define different signal behavior (i.e. output frequency and pulse length) depending on whether or not the receiver is locked to a reliable time source. Time pulse signal can be configured using the configuration group CFG-TP-*

3.11.1.5 Configuring time pulse with CFG-TP-*

The configuration group CFG-TP-* can be used to change the time pulse settings, and includes the following parameters defining the pulse:

- **timepulse enable** - Time pulse is active if this item is set.
- **frequency/period type** - Determines whether the time pulse is interpreted as frequency or period.
- **length/ratio type** - Determines whether the time pulse length is interpreted as length[us] or pulse ratio[%].
- **antenna cable delay** - Signal delay due to the cable between antenna and receiver.
- **pulse frequency/period** - Frequency or period time of the pulse when locked mode is not configured or active.
- **pulse frequency/period lock** - Frequency or period time of the pulse, as soon as receiver has calculated a valid time from a received signal. Only used if the corresponding item is set to use another setting in locked mode.
- **pulse length/ratio** - Length or duty cycle of the generated pulse, either specifies a time or ratio for the pulse to be on/off.
- **pulse length/ratio lock** - Length or duty cycle of the generated pulse, as soon as receiver has calculated a valid time from a received signal. Only used if the corresponding item is set to use another setting in locked mode.
- **user delay** - The cable delay from the receiver to the user device plus signal delay of any user application.
- **lock to GNSS freq** - Use frequency gained from GNSS signal information rather than local oscillator's frequency if item is set.
- **locked other setting** - If this item is set, as soon as the receiver can calculate a valid time, the alternative setting is used. This mode can be used for example to disable time pulse if time is not locked, or indicate lock with different duty cycles.
- **align to TOW** - If this item is set, pulses are aligned to the top of a second.
- **polarity** - If set, the first edge of the pulse is a rising edge (pulse polarity: rising).
- **grid UTC/GNSS** - Selection between UTC (0), GPS (1), GLONASS (2) and BeiDou (3) timegrid. Also affects the time output by UBX-TIM-TP message.

 The maximum pulse length cannot exceed the pulse period.

 Time pulse settings shall be chosen in such a way, that neither the high nor the low period of the output is less than 50 ns (except when disabling it completely), otherwise pulses can be lost.

3.11.1.5.1 Example

The example below shows the 1PPS TIMEPULSE signal generated on the time pulse output according to the specific parameters of the CFG-TP-* configuration group:

- **CFG-TP-TP1_ENA** = 1
- **CFG-TP-PERIOD_TP1** = 100 000 μ s
- **CFG-TP-LEN_TP1** = 100 000 μ s
- **CFG-TP-TIMEGRID_TP1** = 1 (GPS)
- **CFG-TP-PULSE_LENGTH_DEF** = 0 (Period)
- **CFG-TP-ALIGN_TO_TOW_TP1** = 1
- **CFG-TP-USE_LOCKED_TP1** = 1

- `CFG-TP-POL_TP1 = 1`
- `CFG-TP-PERIOD_LOCK_TP1 = 100 000 μs`
- `CFG-TP-LEN_LOCK_TP1 = 100 000 μs`

The 1 Hz output is maintained whether or not the receiver is locked to GPS time. The alignment to TOW can only be maintained when GPS time is locked.

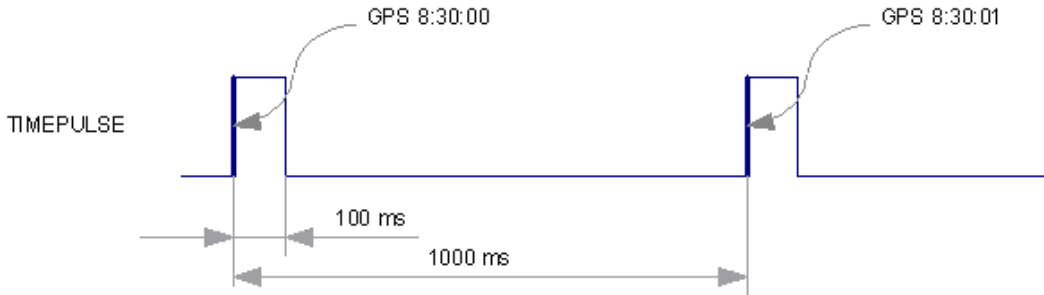

Figure 25: Time pulse signal with the example parameters

3.11.2 Timemark

The receiver can be used to provide an accurate measurement of the time at which a pulse was detected on the external interrupt pin. The reference time can be chosen by setting the time source parameter to UTC, GPS, GLONASS, BeiDou, Galileo or local time in the `CFG-TP-*` configuration group. The UTC standard can be set in the `CFG-NAVSPG-*` configuration group. The delay figures defined with `CFG-TP-*` are also applied to the results output in the `UBX-TIM-TM2` message.

A `UBX-TIM-TM2` message is output at the next epoch if

- The `UBX-TIM-TM2` message is enabled, or
- A rising or falling edge was triggered since last epoch on one of the `EXTINT` channels.

The `UBX-TIM-TM2` messages includes the time of the last timemark, new rising/falling edge indicator, time source, validity, number of marks and a quantization error. The timemark is triggered continuously.



Only the last rising and falling edge detected between two epochs is reported since the output rate of the `UBX-TIM-TM2` message corresponds to the measurement rate configured with `CFG-RATE-MEAS` (see [Figure 26](#) below).

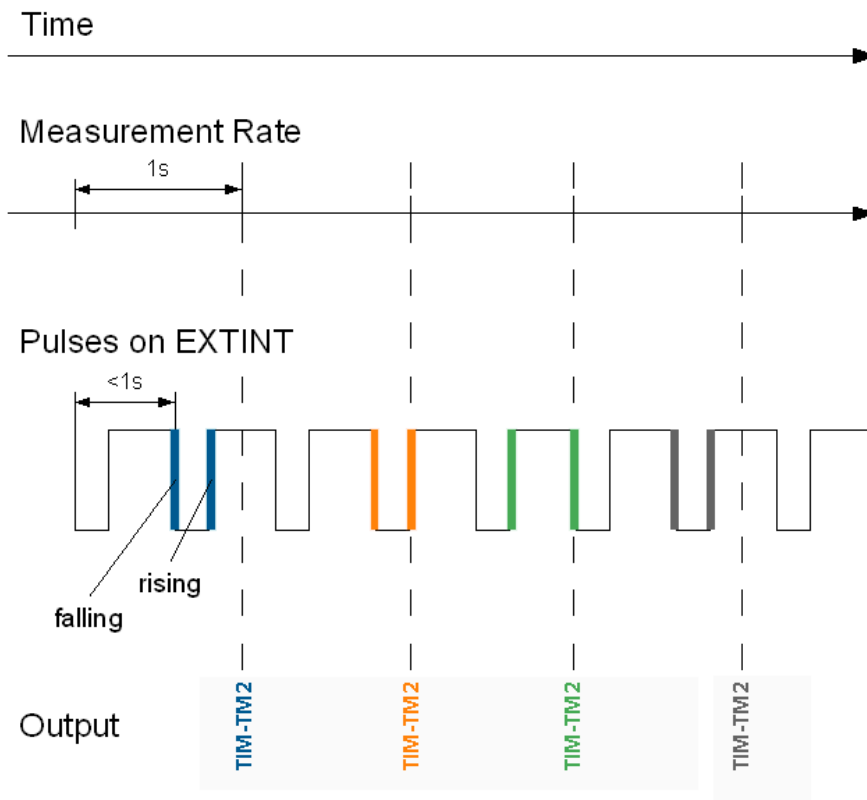

Figure 26: Timemark

3.12 Security

The security concept of ZED-F9P covers the air interface between the receiver and the GNSS satellites and the integrity of the receiver itself.

There are functions to monitor/detect certain security threads and report it to the host system. Other functions try to mitigate the thread and allow the receiver to operate normally.

The table below gives an overview about possible threads and which functionality is available to detect and/or mitigate it.

Threat	u-blox solution
Over air signal integrity	Spoofing detection/mitigation
	Jamming detection/mitigation
GNSS receiver integrity	Secure boot
	Secure firmware update

Table 27: u-blox security options

3.12.1 Spoofing detection / monitoring

Spoofing is the process whereby someone tries to forge a GNSS signal with the intention of fooling the receiver into calculating a different user position than the true one.

The spoofing detection feature monitors the GNSS signals for suspicious patterns indicating that the receiver is being spoofed. A flag in UBX-NAV-STATUS message (`flags2 - spoofDetState`) alerts the user to potential spoofing.

The spoofing detection feature monitors suspicious changes in the GNSS signal indicating external manipulation. Therefore the detection is only successful when the signal is genuine first and when the transition to the spoofed signal is being observed directly. When a receiver is started up to a spoofed signal the detection algorithms will be unable to recognize the spoofing. Also, the algorithms rely on availability of signals from multiple GNSS constellations; the detection does not work in single-GNSS mode.

3.12.2 Jamming/interference indicator

The field `jamInd` of the UBX-MON-RF message can be used as an indicator for continuous wave (narrow-band) jammers/interference only. The interpretation of the value depends on the application. It is necessary to run the receiver in an unjammed environment to determine an appropriate threshold for the unjammed case. If the value rises significantly above this threshold, this indicates that a continuous wave jammer is present.

This monitoring function is always enabled.

The indicator reports any currently detected narrow-band interference over all currently configured signal bands.

3.12.2.1 Jamming/interference monitor (ITFM) / broadband interference monitoring

The field `flags` of the UBX-MON-RF message can be used as an indicator for both broadband and continuous wave (CW) jammers/interference. It is independent of the (CW only) jamming indicator described in [Jamming/interference indicator](#) above.

This monitor reports whether jamming has been detected or suspected by the receiver. The receiver monitors the background noise and looks for significant changes. Normally, with no interference detected, it will report "OK". If the receiver detects that the noise has risen above a preset threshold, the receiver reports "Warning". If in addition, there is no current valid fix, the receiver reports "Critical".

The monitor has four states as shown in the following table:

Value	Reported state	Description
0	Unknown	Jamming/interference monitor not enabled, uninitialized or antenna disconnected
1	OK	no interference detected
2	Warning	position OK but interference is visible (above the thresholds)
3	Critical	no reliable position fix and interference is visible (above the thresholds); interference is probable reason why there is no fix

Table 28: Jamming/interference monitor reported states

The monitor is disabled by default. The monitor is enabled by setting the CFG-ITFM-ENABLE configuration item. In this message it is also possible to specify the thresholds at which broadband and CW jamming are reported. These thresholds should be interpreted as the dB level above "normal". It is also possible to specify whether the receiver expects an active or a passive antenna.



The monitoring algorithm relies on comparing the currently measured spectrum with a reference from when a good fix was obtained. Thus the monitor will only function when the receiver has had at least one (good) first fix, and will report "Unknown" before this time.

The monitor is reporting any currently detected interference over all currently configured signal bands.

3.12.3 GNSS receiver integrity

3.12.3.1 Secure boot

The ZED-F9P boots only with firmware images that are signed by u-blox. This prevents the execution of non-genuine firmware images run on the receiver.

3.12.3.2 Secure firmware update

The firmware image itself is encrypted and signed by u-blox. The ZED-F9P verifies the signature at each start.

3.13 u-blox protocol feature descriptions

3.13.1 Broadcast navigation data

This section describes the data reported via UBX-RXM-SFRBX.

The UBX-RXM-SFRBX reports the broadcast navigation data message collected by the receiver from each tracked signal. When enabled, a separate message is generated every time the receiver decodes a complete subframe of data from a tracked signal. The data bits are reported, as received, including preambles and error checking bits as appropriate. However because there is considerable variation in the data structure of the different GNSS signals, the form of the reported data also varies. Indeed, although this document uses the term "subframe" generically, it is not strictly the correct term for all GNSS (e.g. GLONASS has "strings" and Galileo has "pages").

3.13.1.1 Parsing navigation data subframes

Each UBX-RXM-SFRBX message contains a subframe of data bits appropriate for the relevant GNSS, delivered in a number of 32-bit words, as indicated by numWords field.

Due to the variation in data structure between different GNSS, the most important step in parsing a UBX-RXMSFRBX message is to identify the form of the data. This should be done by reading the gnssId field, which indicates which GNSS the data was decoded from. In almost all cases, this is sufficient to indicate the structure and the following sections are organized by GNSS for that reason. However, in some cases the identity of the GNSS is not sufficient, and this is described, where appropriate, in the following sections.

In most cases, the data does not map perfectly into a number of 32-bit words and, consequently, some of the words reported in UBX-RXM-SFRBX messages contain fields marked as "Pad". These fields should be ignored and no assumption should be made about their contents.

UBX-RXM-SFRBX messages are only generated when complete subframes are detected by the receiver and all appropriate parity checks have passed.

Where the parity checking algorithm requires data to be inverted before it is decoded (e.g. GPS L1C/A), the receiver carries this out before the message output. Therefore, users can process data directly and do not need to worry about repeating any parity processing.

The meaning of the content of each subframe depends on the sending GNSS and is described in the relevant Interface Control Documents (ICD).

3.13.1.2 GPS

The data structure in the GPS L1C/A and L2C signals is dissimilar and thus the UBX-RXM-SFRBX message structure differs as well. For the GPS L1C/A and L2C signals it is as follows:

3.13.1.2.1 GPS L1C/A

For GPS L1C/A signals, there is a fairly straightforward mapping between the reported subframe and the structure of subframe and words described in the GPS ICD. Each subframe comprises ten data words, which are reported in the same order they are received.

Each word is arranged as follows:

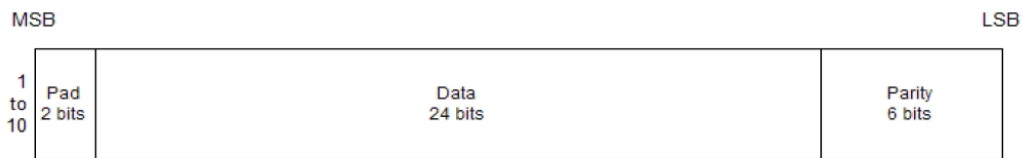

Figure 27: GPS L1C/A subframe word

3.13.1.2.2 GPS L2C

For GPS L2C signals each reported subframe contains the CNAV message as described in the GPS ICD. The ten words are arranged as follows:

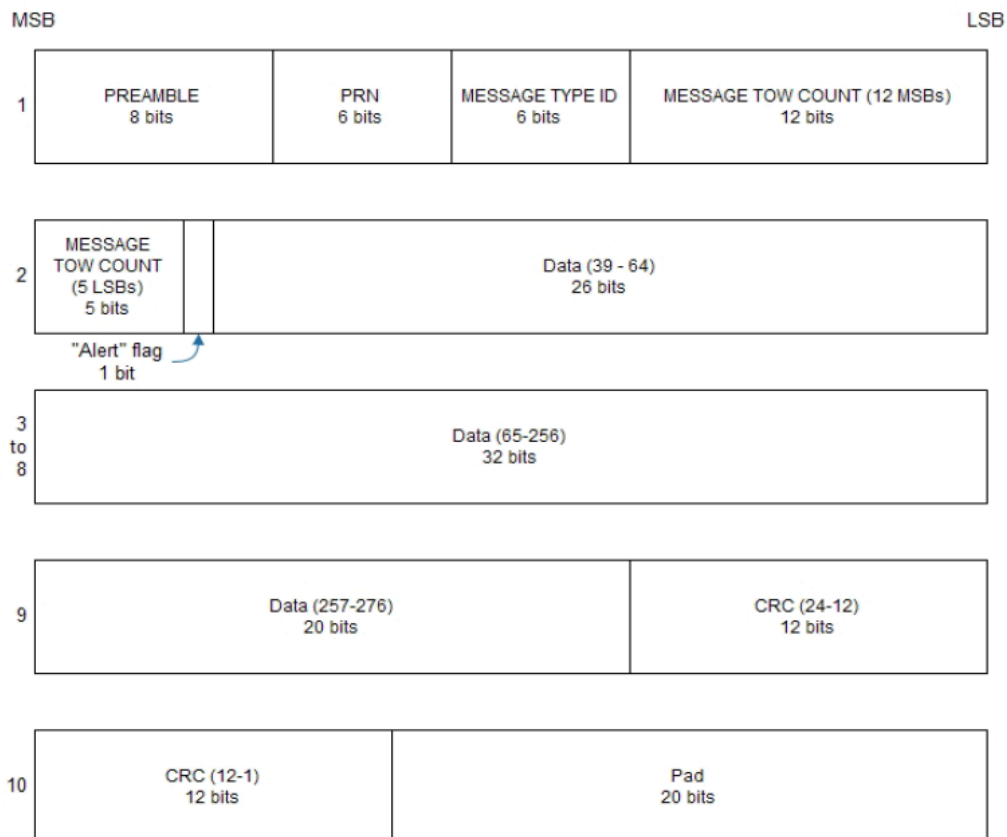

Figure 28: GPS L2C subframe words

3.13.1.3 GLONASS

For GLONASS L1OF and L2OF signals, each reported subframe contains a string as described in the GLONASS ICD. This string comprises 85 data bits which are reported over three 32-bit words in the UBX-RXM-SFRBX message. Data bits 1 to 8 are always a hamming code, whilst bits 81 to 84 are a string number and bit 85 is the idle chip, which should always have a value of zero. The meaning of other bits vary with string and frame number.

The fourth and final 32-bit word in the UBX-RXM-SFRBX message contains frame and superframe numbers (where available). These values are not actually transmitted by the SVs, but are deduced by the receiver and are included to aid decoding of the transmitted data. However, the receiver does not always know these values, in which case a value of zero is reported.

The four words are arranged as follows:

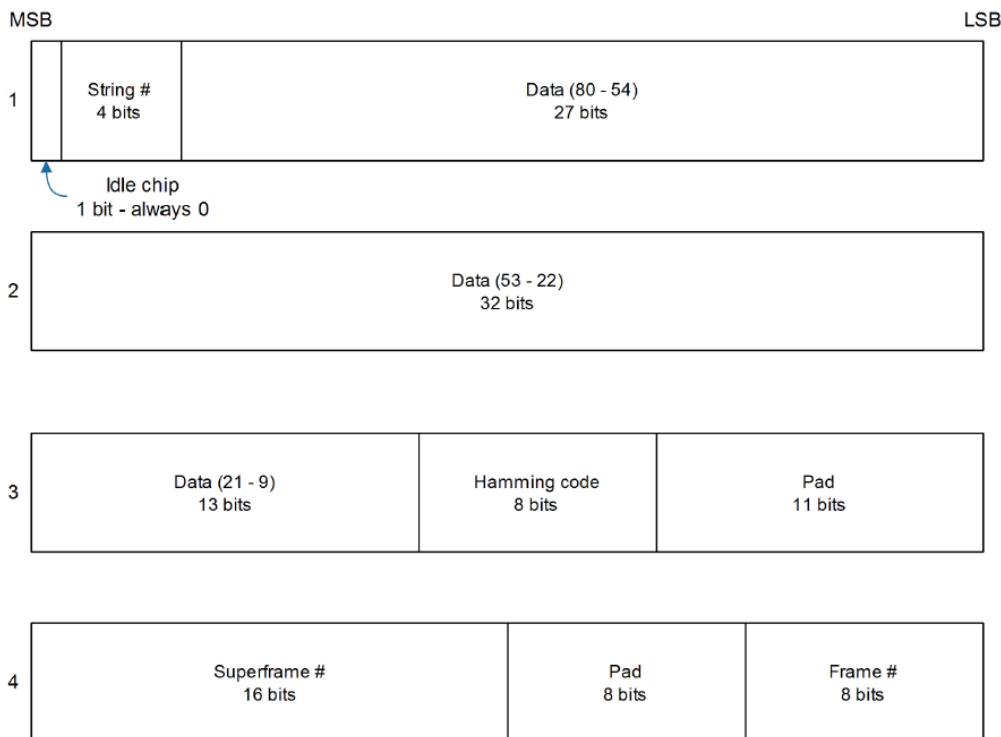

Figure 29: GLONASS subframe words

In some circumstances, (especially on startup) the receiver may be able to decode data from a GLONASS SV before it can identify the SV. When this occurs UBX-RXM-SFRBX messages will be issued with an svId of 255 to indicate "unknown".

3.13.1.4 BeiDou

For BeiDou B1I D1, B1I D2, B2I D1, B2I D2 signals, there is a fairly straightforward mapping between the reported subframe and the structure of subframe and words described in the BeiDou ICD. Each subframe comprises ten data words, which are reported in the same order they are received.

Each word is arranged as follows:

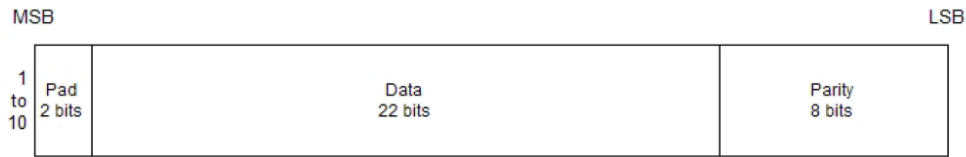

Figure 30: BeiDou subframe word

Note that as the BeiDou data words only comprise 30 bits, the 2 most significant bits in each word reported by UBX-RXM-SFRBX are padding and should be ignored.

3.13.1.5 Galileo

The Galileo E1 C/B and E5 bI/bQ signals both transmit the I/NAV message but in different configurations. The UBX-RXM-SFRBX structures for them are as follows.

3.13.1.5.1 Galileo E1 C/B

For Galileo E1 C/B signals, each reported subframe contains a pair of I/NAV pages as described in the Galileo ICD.

For Galileo "Nominal" pages the eight words are arranged as follows:

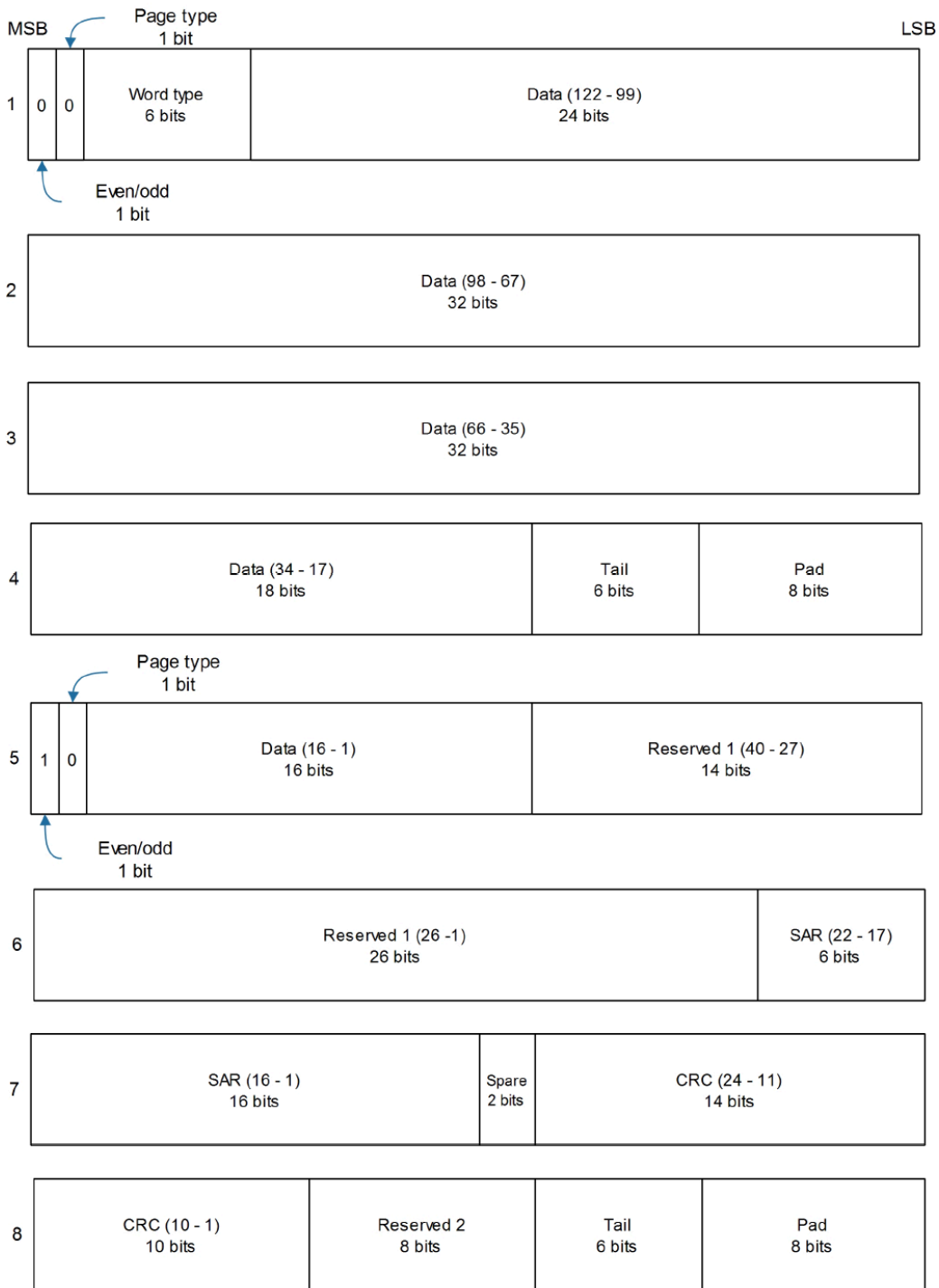

Figure 31: Galileo E1 C/B subframe words

3.13.1.5.2 Galileo E5 bl/bQ

For Galileo E5 bl/bQ signals, each reported subframe contains a pair of I/NAV pages as described in the Galileo ICD. Galileo pages can either be "Nominal" or "Alert" pages. For Nominal pages the eight words are arranged as follows:

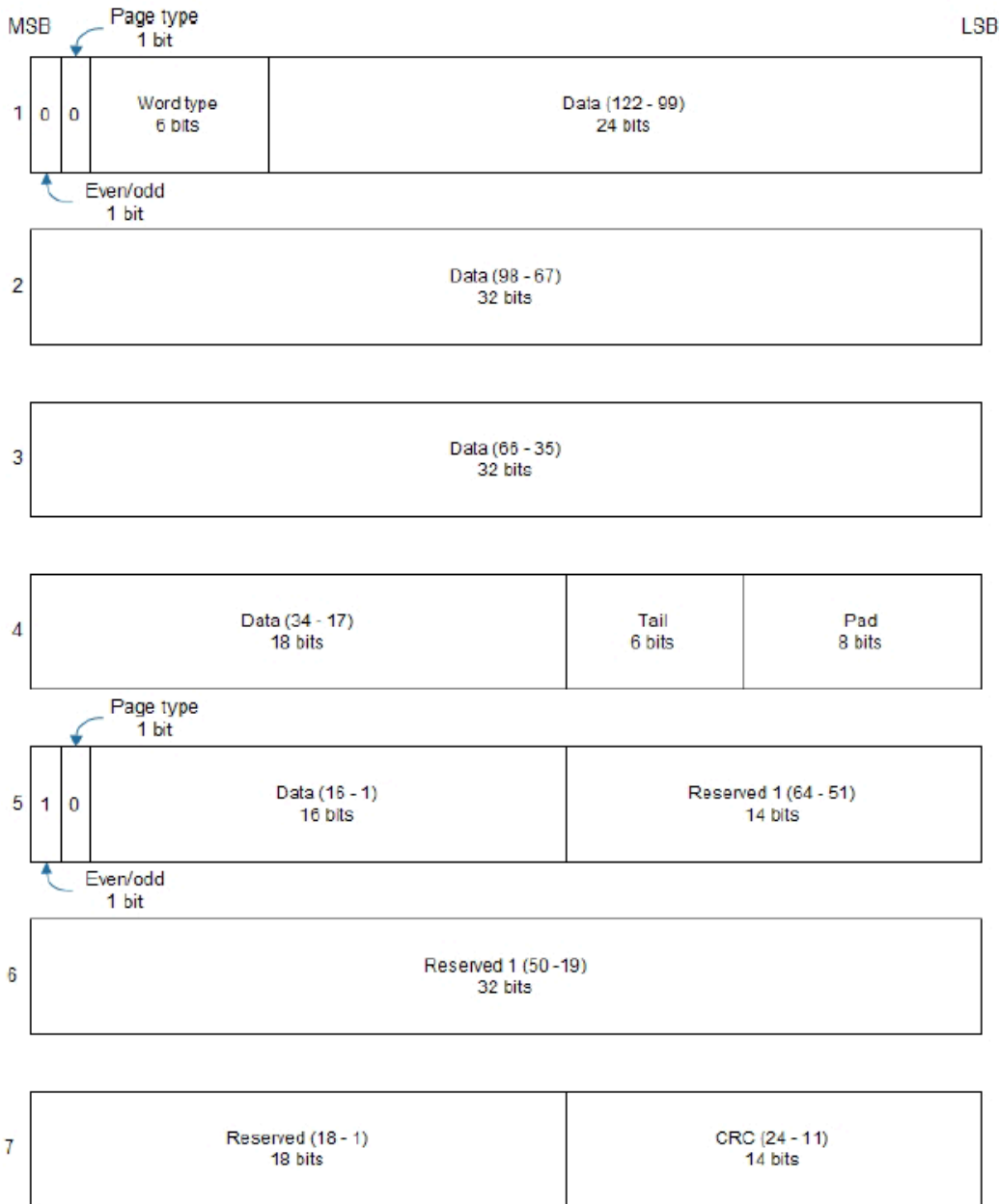

Figure 32: Galileo E5 bI/bQ subframe words

Alert pages are reported in very similar manner, but the page type bits will have value 1 and the structure of the eight words will be slightly different (as indicated by the Galileo ICD).

3.13.1.6 SBAS

For SBAS (L1C/A) signals each reported subframe contains eight 32 data words to deliver the 250 bits transmitted in each SBAS data block.

The eight words are arranged as follows:

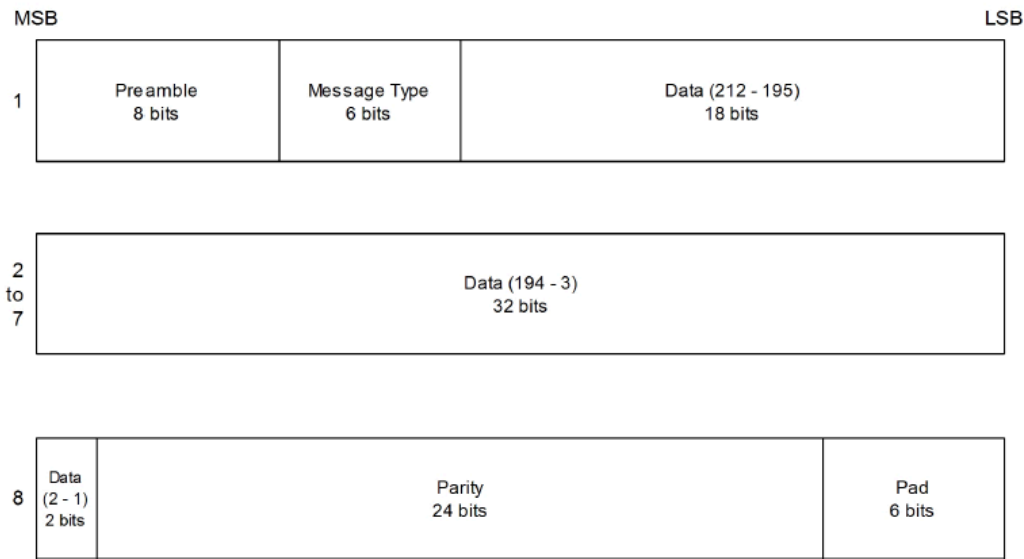
Figure 33: SBAS subframe words

3.13.1.7 QZSS

The structure of the data delivered by QZSS L1C/A signals is effectively identical to that for GPS (L1C/A). Similarly the structure of the data delivered by the QZSS L2C signal is effectively identical to GPS (L2C). Similarly the structure of the data delivered by the QZSS L1S signal is effectively identical to SBAS (L1C/A).

3.13.1.8 Summary

The following table gives a summary of the different data message formats reported by the UBX-RXM-SFRBX message:

GNSS	Signal	gnssId	sigId	numWords	period
GPS	L1C/A	0	0	10	6s
SBAS	L1C/A	1	0	8	1s
GPS	L2CL	0	3	10	12s
GPS	L2CM	0	4	10	12s
Galileo	E1 C	2	0	8	2s
Galileo	E1 B	2	1	8	2s
Galileo	E5 bl	2	5	8	2s
Galileo	E5 bQ	2	6	8	2s
BeiDou	B1I D1	3	0	10	6s
BeiDou	B1I D2	3	1	10	0.6s
BeiDou	B2I D1	3	2	10	0.6s
BeiDou	B2I D2	3	3	10	0.6s
QZSS	L1C/A	5	0	10	6s
QZSS	L1S	5	1	8	1s
QZSS	L2CM	5	4	10	12s
QZSS	L2CL	5	5	10	12s
GLONASS	L1OF	6	0	4	2s

GNSS	Signal	gnssId	sigId	numWords	period
GLONASS	L2OF	6	2	4	2s

Table 29: Data message formats reported by UBX-RXM-SFRBX

3.14 Forcing a receiver reset

Typically, in GNSS receivers, a distinction is made between cold, warm, and hot start, depending on the type of valid information the receiver has at the time of the restart.

- **Cold start:** In cold start mode, the receiver has no information from the last position (e.g. time, velocity, frequency etc.) at startup. Therefore, the receiver must search the full time and frequency space, and all possible satellite numbers. If a satellite signal is found, it is tracked to decode the ephemeris (18-36 seconds under strong signal conditions), whereas the other channels continue to search satellites. Once there is a sufficient number of satellites with valid ephemeris, the receiver can calculate position and velocity data. Other GNSS receiver manufacturers call this startup mode **Factory startup**.
- **Warm start:** In warm start mode, the receiver has approximate information for time, position, and coarse satellite position data (Almanac). In this mode, after power-up, the receiver normally needs to download ephemeris before it can calculate position and velocity data. As the ephemeris data usually is outdated after 4 hours, the receiver will typically start with a warm start if it has been powered down for more than 4 hours. In this scenario, several augmentations are possible. See [Multiple GNSS assistance](#).
- **Hot start:** In hot start mode, the receiver was powered down only for a short time (4 hours or less), so that its ephemeris is still valid. Since the receiver does not need to download ephemeris again, this is the fastest startup method.

Using the UBX-CFG-RST message, you can force the receiver to reset and clear data, in order to see the effects of maintaining/losing such data between restarts. For this, the UBX-CFG-RST message offers the `navBbrMask` field, where hot, warm and cold starts can be initiated, and also other combinations thereof.

The reset type can also be specified. This is not related to GNSS, but to the way the software restarts the system.

- **Hardware reset** uses the on-chip watchdog, in order to electrically reset the chip. This is an immediate, asynchronous reset. No Stop events are generated.
- **Controlled software reset** terminates all running processes in an orderly manner and, once the system is idle, restarts operation, reloads its configuration and starts to acquire and track GNSS satellites.
- **Controlled software reset (GNSS only)** only restarts the GNSS tasks, without reinitializing the full system or reloading any stored configuration.
- **Hardware reset** uses the on-chip watchdog. This is a reset after shutdown.
- **Controlled GNSS stop** stops all GNSS tasks. The receiver will not be restarted, but will stop any GNSS-related processing.
- **Controlled GNSS start** starts all GNSS tasks.

3.15 Spectrum analyzer

The receiver has an integrated spectrum analyzer. The spectrum analyzer can be used during the design-in process of the receiver to detect spurious emissions from other applications in the GNSS bands.

To report the spectrum information, enable the UBX-MON-SPAN message (see ZED-F9P Interface description [2]). The UBX-MON-SPAN message view visualizes the spectrum information in u-center.

4 Design

This section provides information to help carry out a successful schematic and PCB design integrating the ZED-F9P.

Do not load Pin 4 (ANT_DETECT) with a capacitance more than 1 nF.

4.1 Pin assignment

The pin assignment of the ZED-F9P module is shown in [Figure 34](#). The defined configuration of the PIOs is listed in [Table 30](#).

The ZED-F9P is an LGA package with the I/O on the outside edge and central ground pads.

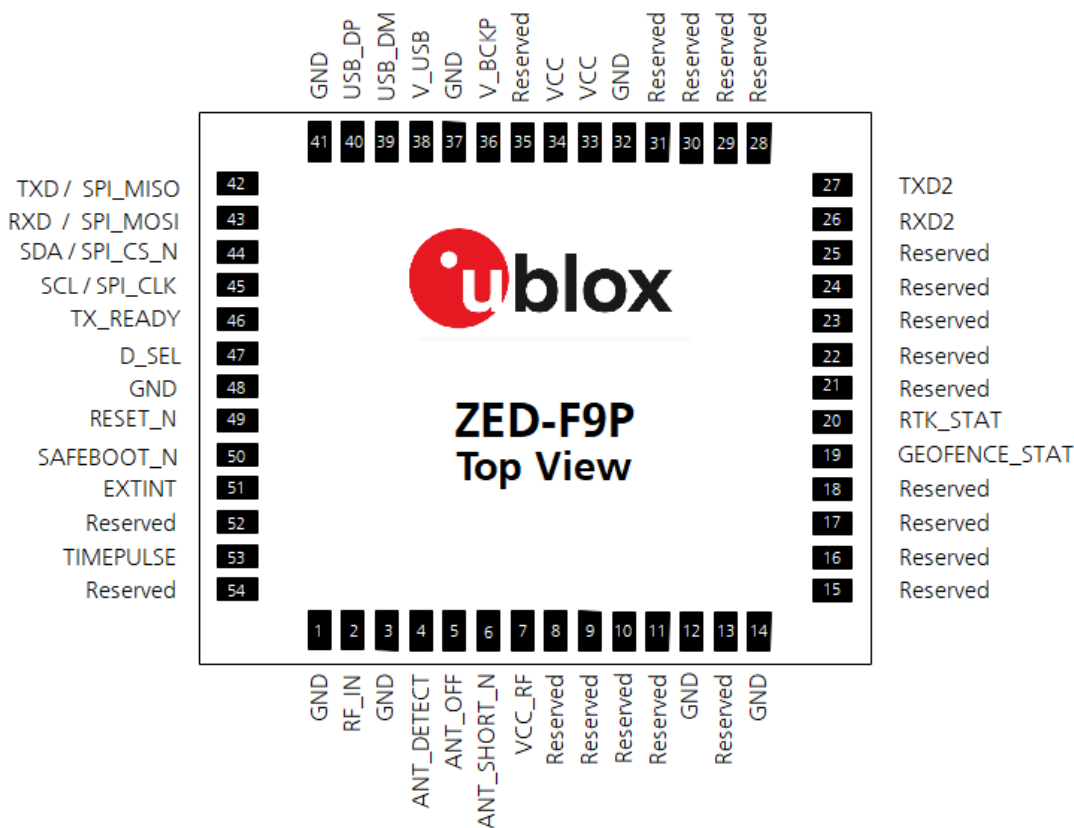

Figure 34: ZED-F9P pin assignment

Pin No	Name	I/O	Description
1	GND	-	Ground
2	RF_IN	I	RF input
3	GND	-	Ground
4	ANT_DETECT	I	Active antenna detect - default active high
5	ANT_OFF	O	External LNA disable - default active high
6	ANT_SHORT_N	I	Active antenna short detect - default active low
7	VCC_RF	O	Voltage for external LNA
8	Reserved	-	Reserved

Pin No	Name	I/O	Description
9	Reserved	-	Reserved
10	Reserved	-	Reserved
11	Reserved	-	Reserved
12	GND	-	Ground
13	Reserved	-	Reserved
14	GND	-	Ground
15	Reserved	-	Reserved
16	Reserved	-	Reserved
17	Reserved	-	Reserved
18	Reserved	-	Reserved
19	GEOFENCE_STAT	O	Geofence status, user defined
20	RTK_STAT	O	RTK status: 0 (RTK fixed), Blinking (receiving and using RTCM corrections), 1 (otherwise)
21	Reserved	-	Reserved
22	Reserved	-	Reserved
23	Reserved	-	Reserved
24	Reserved	-	Reserved
25	Reserved	-	Reserved
26	RXD2	I	Correction UART input
27	TXD2	O	Correction UART output
28	Reserved	-	Reserved
29	Reserved	-	Reserved
30	Reserved	-	Reserved
31	Reserved	-	Reserved
32	GND	-	Ground
33	VCC	I	Voltage supply
34	VCC	I	Voltage supply
35	Reserved	-	Reserved
36	V_BCKP	I	Backup supply voltage
37	GND	-	Ground
38	V_USB	I	USB supply
39	USB_DM	I/O	USB data
40	USB_DP	I/O	USB data
41	GND	-	Ground
42	TXD / SPI_MISO	O	Host UART output if D_SEL = 1 (or open). SPI_MISO if D_SEL = 0
43	RXD / SPI_MOSI	I	Host UART input if D_SEL = 1 (or open). SPI_MOSI if D_SEL = 0
44	SDA / SPI_CS_N	I/O	I2C Data if D_SEL = 1 (or open). SPI Chip Select if D_SEL = 0
45	SCL / SPI_CLK	I/O	I2C Clock if D_SEL = 1 (or open). SPI Clock if D_SEL = 0
46	TX_READY	O	TX_Buffer full and ready for TX of data
47	D_SEL	I	Interface select for pins 42-45
48	GND	-	Ground
49	RESET_N	I	RESET_N
50	SAFEBOOT_N	I	SAFEBOOT_N (for future service, updates and reconfiguration, leave OPEN)
51	EXTINT	I	External Interrupt Pin

Pin No	Name	I/O	Description
52	Reserved	-	Reserved
53	TIMEPULSE	O	Time pulse
54	Reserved	-	Reserved

Table 30: ZED-F9P pin assignment





4.2 Power supply

The u-blox ZED-F9P module has three power supply pins: VCC, V_BCKP and V_USB.

4.2.1 VCC: Main supply voltage

The **VCC** pin is connected to the main supply voltage. During operation, the current drawn by the module can vary by some orders of magnitude. For this reason, it is important that the supply circuitry be able to support the peak power for a short time (see the ZED-F9P Data sheet [1] for specification).

The module integrates a DC/DC converter, which allows reduced power consumption.





-  When switching from backup mode to normal operation or at start-up, u-blox ZED-F9P modules must charge the internal capacitors in the core domain. In certain situations, this can result in a significant current draw. For low-power applications using backup mode, it is important that the power supply or low ESR capacitors at the module input can deliver this current/charge.
-  To reduce peak current during power on, users can employ an LDO that has an in-built current limiter.
-  Do not add any series resistance greater than 0.2 Ω to the VCC supply as it will generate input voltage noise due to dynamic current conditions.
-  For the ZED-F9P module the equipment must be supplied by an external limited power source in compliance with the clause 2.5 of the standard IEC 60950-1.

4.2.2 V_BCKP: Backup supply voltage

If the module supply has a power failure, the **V_BCKP** pin supplies the real-time clock (RTC) and battery backed RAM (BBR). Use of valid time and the GNSS orbit data at start up will improve the GNSS performance, as with hot starts and warm starts.

If V_BCKP is not provided, the module performs a cold start at power up.

If a host is connected to ZED-F9P, V_BCKP can be partially emulated by using UBX-UPD-SOS functionality. BBR data can be saved to the host and restored at startup. See [Interface description](#) for more information.

-  Avoid high resistance on the **V_BCKP** line: During the switch from main supply to backup supply, a short current adjustment peak can cause a high voltage drop on the pin with possible malfunctions.
-  Add a 2 μF capacitor on the V_BCKP pin to absorb the current adjustment peak when switching from VCC to V_BCKP supply.
-  If no backup supply voltage is available, connect the **V_BCKP** pin to **VCC**.
-  Allow all I/O including UART and other interfaces to float or connect to a high impedance in HW backup mode (V_BCKP supplied when VCC is removed). See the [Interfaces](#) section.

Real time clock (RTC)

The real-time clock (RTC) is driven by a 32-kHz oscillator using an RTC crystal. If VCC is removed whilst a battery is connected to **V_BCKP**, most of the receiver is switched off leaving the RTC and BBR powered. This operating mode is called Hardware Backup Mode which enables time keeping and all relevant data to be saved to allow a hot or warm start.

4.2.3 ZED-F9P power supply

The ZED-F9P high precision receiver requires a low-noise, low-dropout voltage, and a very low source impedance power supply of 3.3 V typically. No inductors or ferrite beads should be used from LDO to the module VCC pin. The peak currents need to be taken into account for the source supplying the LDO for the module.

A power supply fed by 5 V is shown in the figure below. This example circuit is intended only for the module supply.

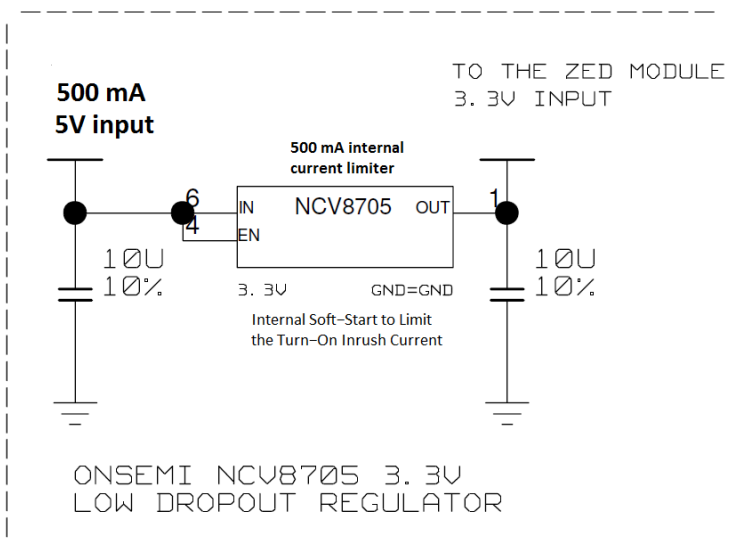

Figure 35: ZED-F9P power supply

4.3 ZED-F9P minimal design

The minimal electrical circuit for ZED-F9P operation using the UART1 interface is shown in [Figure 36](#) below.

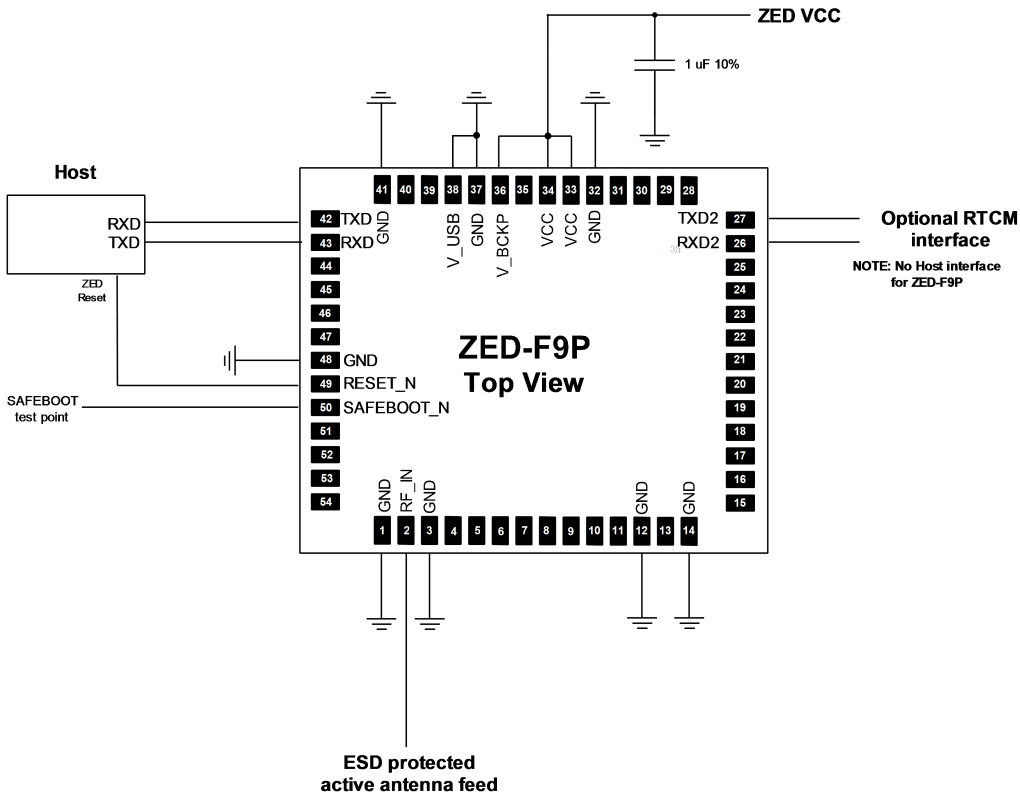

Figure 36: Minimal ZED-F9P design

For a minimal design with the ZED-F9P GNSS modules, the following functions and pins should be considered:

- Connect the power supply to VCC and V_BCKP.
- If hot or warm start operations are needed, connect a backup battery to V_BCKP.
- If USB is not used connect V_USB to ground.
- Ensure an optimal ground connection to all ground pins of the ZED-F9P GNSS module.
- If antenna bias is required, see ZED-F9P [antenna bias](#) section.

The host interface typically supplies the RTCM messages required for RTK operation.

4.4 Antenna

u-blox recommends using an active antenna with ZED-F9P.

If an active antenna needs to be implemented in an application case, it is recommended that an OEM active antenna module be used that meets our specification. To implement the required RF circuitry and source the required components to meet group delay specification is not a simple process compared to previous L1-only implementation.

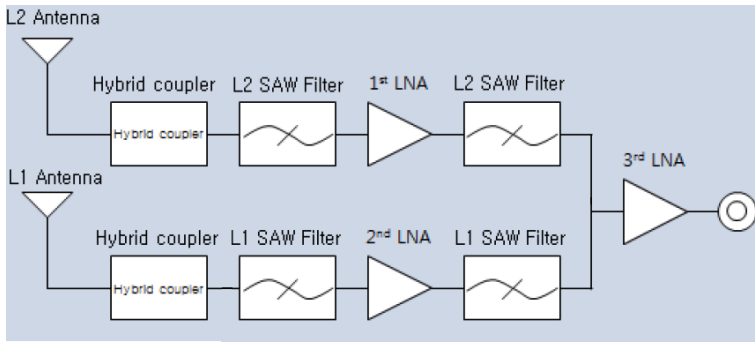

Figure 37: u-blox low cost dual-band antenna internal structure

- A suitable ground plane is required for the antenna to achieve good performance.
- Location of the antenna is critical to reach the stated performance. Unsuitable locations could include, under vehicle dash, rear-view mirror location, etc.

L1 + L2/E5b active antenna required specifications

Parameter	Specification	
Antenna type	Active antenna	
Active antenna recommendations	Minimum active antenna gain ³	17 dB
	Maximum active antenna gain ³	50 dB
	Noise figure	<4 dB
L1 band antenna gain ⁴	1559 - 1606 MHz: 3 dBic typ.	
L2/E5b band antenna gain ⁵	1197 - 1249 MHz: 2 dBic typ.	
Polarization	RHCP	
Axial ratio	2 dB max at Zenith	
Phase center variation	<10 mm over elevation/azimuth	
Group delay variation in-band ⁶	10 ns max at each GNSS system bandwidth. Note: Inter-signal requirement 50 ns max.	
EMI immunity out-of-band ⁷	30 V/m	
Out-of-band ⁸ rejection	40 dB typ	
ESD circuit protection	15 kV human body model air discharge	

Table 31: Antenna specifications for ZED-F9P modules

³ Including passive losses (filters, cables, connectors etc.)

⁴ Measured with a ground plane d=150 mm

⁵ Measured with a ground plane d=150 mm

⁶ GNSS system bandwidths: 1559... 1563 MHz; 1573... 1578 MHz; 1598... 1606 MHz; 1192... 1212 MHz; 1197... 1217 MHz; 1223... 1231 MHz; 1242... 1249 MHz

⁷ Exception L1 and L2 bands +/- 200 MHz, emphasis on cellular bands

⁸ GNSS system bandwidths: 1559... 1563 MHz; 1573... 1578 MHz; 1598... 1606 MHz; 1192... 1212 MHz; 1197... 1217 MHz; 1223... 1231 MHz; 1242... 1249 MHz

The antenna system should include filtering to ensure adequate protection from nearby transmitters. Take care in the selection of antennas placed close to cellular or Wi-Fi transmitting antennas.

4.4.1 Antenna bias

Active antennas have an integrated low-noise amplifier that contributes an additional current of typically 5 to 20 mA to the system's power consumption budget.

If customers do not want to make use of the antenna supervisor function the filtered VCC_RF supply voltage output can supply the antenna if the supply voltage of the ZED-F9P module matches the antenna working voltage (e.g. 3.0 V).

- ☞ A series current limiting resistor is required to prevent short circuits destroying the bias-t inductor.
- ☞ The bias-t inductor must be chosen for multi-band operation, a value of 120 nH 5% is recommended for the recommended Murata L part. It has a self-resonance frequency of 1 GHz and a high impedance (> 500 Ω) at L-band frequencies.

The recommended bias-t inductor (Murata LQW15ANR12J00) has a maximum current capacity of 110 mA. Hence the current is limited to 70 mA at 3.3V using an active limiter in the recommended circuit shown in Figure 39 below. A 10 Ω resistor (R2) is provided to measure the current. This resistor power rating must be chosen to ensure reliability in the chosen circuit design.

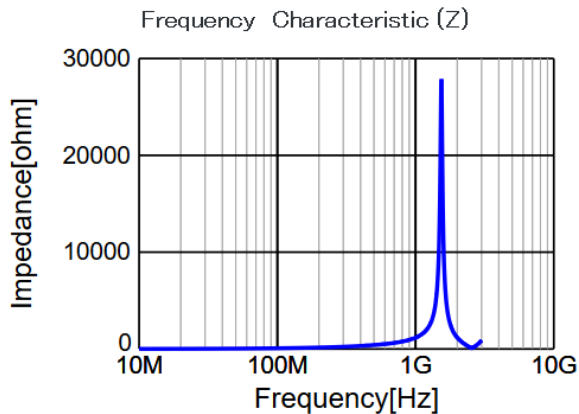

■ [LQW15ANR12J00](#),

Figure 38: ZED-F9P antenna bias inductor impedance

A recommended circuit design for an active antenna bias is shown below. This example shows an external voltage of 3.3 V with current limiting as described above. An ESD protection diode should also be connected to the input as shown.

RF INPUT FOR ZED-F9 AND ANTENNA BIAS

NOTE:

BIAS-CIRCUITRY LIMITS THE CURRENT TO ~70MA

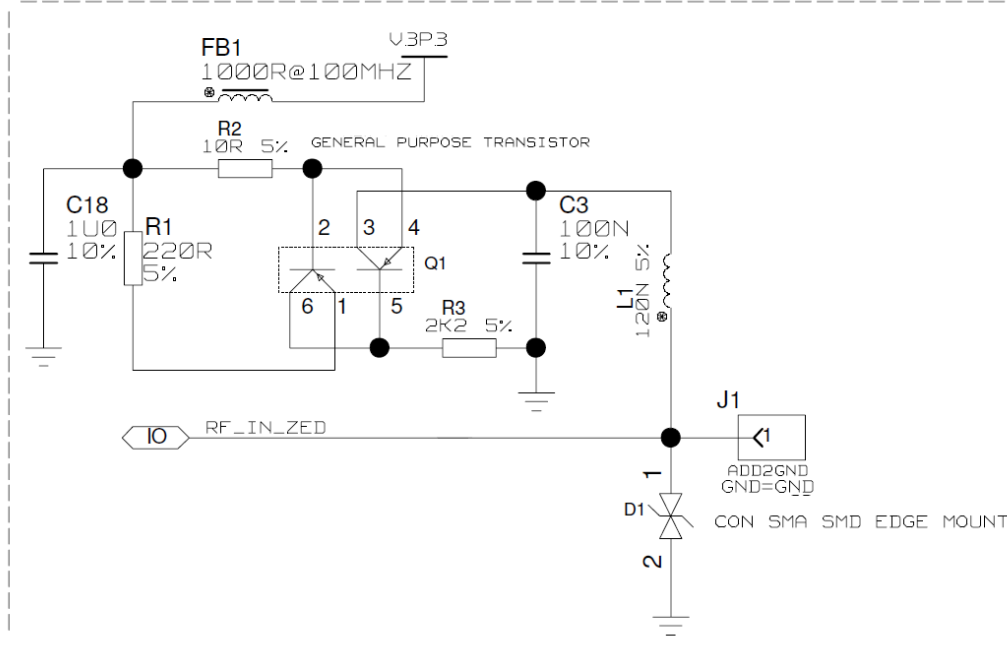
Figure 39: ZED-F9P reference design for antenna bias

L1: MURATA LQW15A LQW15ANR12J00 0402 120N 5% 0.11A -55/+125C

D1: TYCO, 0.25PF, PESD0402-140 -55/+125C

C3: MURATA GRM033R61E104KE14 CER X5R 0201 100N 10% 25V

R2: RES THICK FILM CHIP 1206 10R 5% 0.25W

It is recommended to use active current limiting. If active current limiting is not used, the important points covered below need to be taken into account:

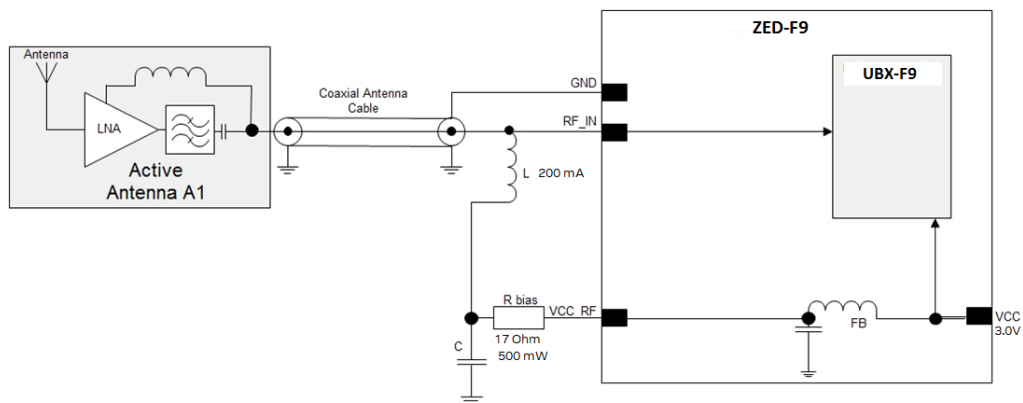
Figure 40: ZED-F9P VCC_RF antenna bias

The bias-t inductor and current limiting resistor must be selected to be reliable with a short-circuit on the antenna feed if no active current limiter is used. Our recommended part has a limit of 110 mA. A part with a higher current capability will be needed if the short circuit current is as described here. This will also be affected by the voltage level of the antenna

bias supply due to power dissipation. Take the current limit capability of the antenna bias supply into consideration. In the case where the module supplies the voltage via VCC_RF, a higher value resistor will be needed to ensure the module supply inductor is protected. The current should be limited to below 150 mA at the module supply voltage under short-circuit conditions. In this case a value of 17 Ω or more is required at a module supply of 3 V to limit short circuit current to 150 mA. The DC resistance of the bias-t inductor is assumed to be 1-2 Ω and the module internal feed inductor is assumed to be 1.2 Ω .

If the VCC_RF voltage does not match with the supply voltage of the active antenna, use a filtered external supply.



The power dissipation in the resistor and inductor needs to be taken into account based on the supply voltage and short circuit current. The bias-t inductor current capability and the bias resistor value need to be calculated as shown above. The supply voltage for the bias-t and its current capability is part of the calculation.

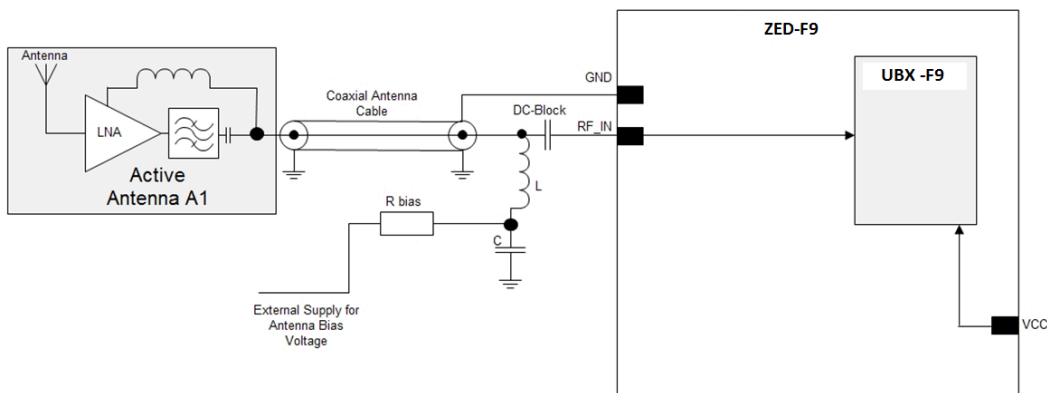

Figure 41: ZED-F9P external voltage antenna bias

4.5 EOS/ESD precautions

When integrating GNSS receivers into wireless systems, careful consideration must be given to electromagnetic and voltage susceptibility issues. Wireless systems include components which can produce Electrostatic Discharge (ESD), Electrical Overstress (EOS) and Electro-Magnetic Interference (EMI). CMOS devices are more sensitive to such influences because their failure mechanism is defined by the applied voltage, whereas bipolar semiconductors are more susceptible to thermal overstress. The following design guidelines are provided to help in designing robust yet cost-effective solutions.

- To avoid overstress damage during production or in the field it is essential to observe strict EOS/ESD/EMI handling and protection measures.
- To prevent overstress damage at the RF_IN of your receiver, never exceed the maximum input power as specified in the u-blox ZED-F9P Data sheet [1].

4.5.1 ESD protection measures

- GNSS receivers are sensitive to Electrostatic Discharge (ESD). Special precautions are required when handling. Most defects caused by ESD can be prevented by following strict ESD protection rules for production and handling. When implementing passive antenna patches or external antenna connection points, then additional ESD measures as shown in the figure below can also avoid failures in the field.

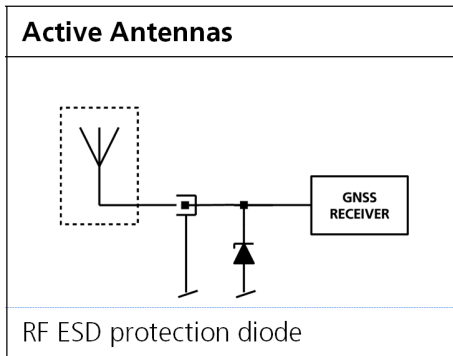

Figure 42: RF ESD precautions

4.5.2 EOS precautions

Electrical overstress (EOS) usually describes situations when the maximum input power exceeds the maximum specified ratings. EOS failure can happen if RF emitters are close to a GNSS receiver or its antenna. EOS causes damage to the chip structures. If the RF_IN is damaged by EOS, it is hard to determine whether the chip structures have been damaged by ESD or EOS.

EOS protection measures as shown in the figure below are recommended for any designs combining wireless communication transceivers (e.g. GSM, GPRS) and GNSS in the same design or in close proximity.

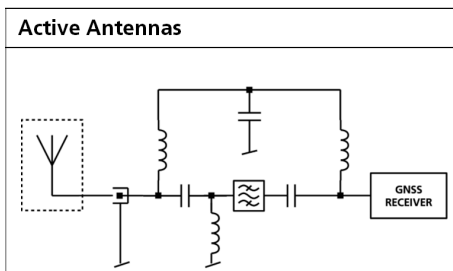

Figure 43: Active antenna EOS protection

4.5.3 Safety precautions

The ZED-F9P must be supplied by an external limited power source in compliance with the clause 2.5 of the standard IEC 60950-1. In addition to external limited power source, only Separated or Safety Extra-Low Voltage (SELV) circuits are to be connected to the module including interfaces and antennas.



For more information about SELV circuits see section 2.2 in Safety standard IEC 60950-1.

4.6 Electromagnetic interference on I/O lines

Any I/O signal line with a length greater than approximately 3 mm can act as an antenna and may pick up arbitrary RF signals transferring them as noise into the receiver. This specifically applies to unshielded lines, in which the corresponding GND layer is remote or missing entirely, and lines close to the edges of the printed circuit board.

If, for example, a cellular signal radiates into an unshielded high-impedance line, it is possible to generate noise in the order of volts and not only distort receiver operation but also damage it permanently. Another type of interference can be caused by noise generated at the PIO pins that

emits from unshielded I/O lines. Receiver performance may be degraded when this noise is coupled into the GNSS antenna.

EMI protection measures are particularly useful when RF emitting devices are placed next to the GNSS receiver and/or to minimize the risk of EMI degradation due to self-jamming. An adequate layout with a robust grounding concept is essential in order to protect against EMI.



Intended Use: In order to mitigate any performance degradation of a radio equipment under EMC disturbance, system integration shall adopt appropriate EMC design practice and not contain cables over three meters on signal and supply ports.

4.6.1 General notes on interference issues

Received GNSS signal power at the antenna is very low. At the nominal received signal strength (-128 dBm) it is below the thermal noise floor of -111 dBm. Due to this fact, a GNSS receiver is susceptible to interference from nearby RF sources of any kind. Two cases can be distinguished:

- Out-of-band interference: Typically any kind of wireless communications system (e.g. LTE, GSM, CDMA, 3G, WLAN, Bluetooth, etc.) may emit its specified maximum transmit power in close proximity to the GNSS receiving antenna, especially if such a system is integrated with the GNSS receiver. Even at reasonable antenna selectivity, destructive power levels may reach the RF input of the GNSS receiver. Also, larger signal interferers may generate intermodulation products inside the GNSS receiver front-end that fall into the GNSS band and contribute to in-band interference
- In-band interference: Although the GNSS band is kept free from intentional RF signal sources by radio-communications standards, many devices emit RF power into the GNSS band at levels much higher than the GNSS signal itself. One reason is that the frequency band above 1 GHz is not well regulated with regards to EMI, and even if permitted, signal levels are much higher than GNSS signal power. Notably, all types of digital equipment, such as PCs, digital cameras, LCD screens, etc. tend to emit a broad frequency spectrum up to several GHz of frequency. Also wireless transmitters may generate spurious emissions that fall into GNSS band.

As an example, GSM uses power levels of up to 2 W (+33 dBm). The absolute maximum power input at the RF input of the GNSS receiver can be +15 dBm. The GSM specification allows spurious emissions for GSM transmitters of up to +36 dBm, while the GNSS signal is less than -128 dBm. By simply comparing these numbers it is obvious that interference issues must be seriously considered in any design of a GNSS receiver. Different design goals may be achieved through different implementations:

- The primary focus is preventing the destruction of the receiver from large input signals. Here the GNSS performance under interference conditions is not important and suppression of the signal is permitted. It is sufficient to just observe the maximum RF power ratings of all the components in the RF input path.
- GNSS performance must be guaranteed even under interference conditions. In that case, not only the maximum power ratings of the components in the receive patch must be observed. Further, non-linear effects like gain compression, NF degradation (desensitization) and intermodulation must be analyzed.



Pulsed interference with a low-duty cycle such as GSM may be destructive due to the high peak power levels.

4.6.2 In-band interference mitigation

With in-band interference, the signal frequency is very close to the GNSS frequency. Such interference signals are typically caused by harmonics from displays, micro-controller operation, bus systems, etc. Measures against in-band interference include:

- Maintaining a good grounding concept in the design
- Shielding
- Layout optimization
- Low-pass filtering of noise sources, e.g. digital signal lines
- Remote placement of the GNSS antenna, far away from noise sources
- Adding an LTE, CDMA, GSM, WCDMA, BT band-pass filter before antenna

4.6.3 Out-of-band interference

Out-of-band interference is caused by signal frequencies that are different from the GNSS carrier frequency. The main sources are wireless communication systems such as LTE, GSM, CDMA, WCDMA, Wi-Fi, BT, etc.

Measures against out-of-band interference include maintaining a good grounding concept in the design and adding a GNSS band-pass filter into the antenna input line to the receiver.

For GSM applications, such as typical handset design, an isolation of approximately 20 dB can be reached with careful placement of the antennas. If this is insufficient, an additional SAW filter is required on the GNSS receiver input to block the remaining GSM transmitter energy.

4.7 Layout

This section details layout and placement requirements of the ZED-F9P high precision receiver.

4.7.1 Placement

GNSS signals at the surface of the Earth are below the thermal noise floor. A very important factor in achieving maximum GNSS performance is the placement of the receiver on the PCB. The placement used may affect RF signal loss from antenna to receiver input and enable interference into the sensitive parts of the receiver chain, including the antenna itself. When defining a GNSS receiver layout, the placement of the antenna with respect to the receiver, as well as grounding, shielding and interference from other digital devices are crucial issues and need to be considered very carefully.

Signal loss on the RF connection from antenna to receiver input must be minimized as much as possible. Hence, the connection to the antenna must be kept as short as possible.

Ensure that RF critical circuits are clearly separated from any other digital circuits on the system board. To achieve this, position the receiver digital part closer to the digital section of the system PCB and have the RF section and antenna placed as far as possible away from the other digital circuits on the board.

A proper GND concept shall be followed: The RF section shall not be subject to noisy digital supply currents running through its GND plane.

Care must also be exercised with placing the receiver in proximity to circuitry that can emit heat. The RF part of the receiver is very sensitive to temperature and sudden changes can have an adverse impact on performance.



The TCXO of a GNSS receiver is a temperature-sensitive device. Avoid high temperature drift and air convection.

4.7.2 Package footprint, copper and paste mask

Copper and solder mask dimensioning recommendations for the ZED-F9P module packages are provided in this section.



These are recommendations only and not specifications. The exact copper, solder and paste mask geometries, distances, stencil thickness and solder paste volumes must be adapted to the specific production processes (e.g. soldering etc.) of the customer.

Refer to the ZED-F9P Data sheet [1] for the mechanical dimensions.

4.7.2.1 Footprint

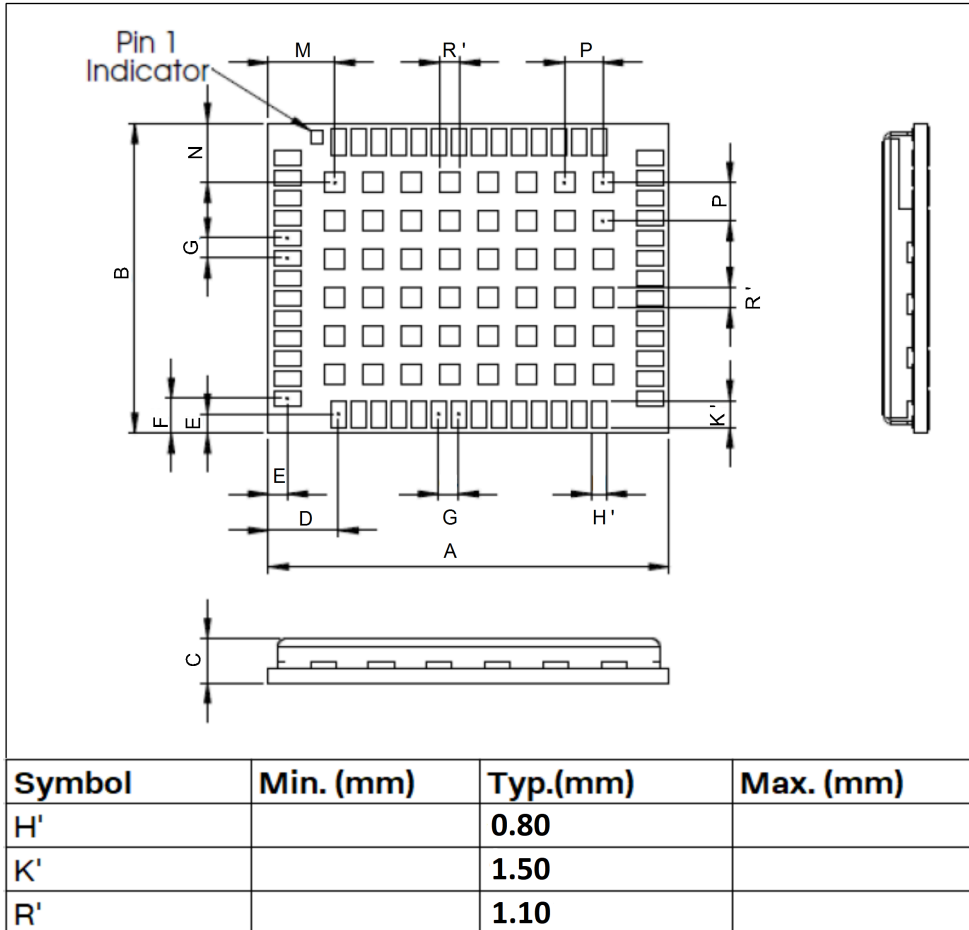

Figure 44: ZED-F9P suggested footprint (i.e. copper mask)

4.7.2.2 Paste mask

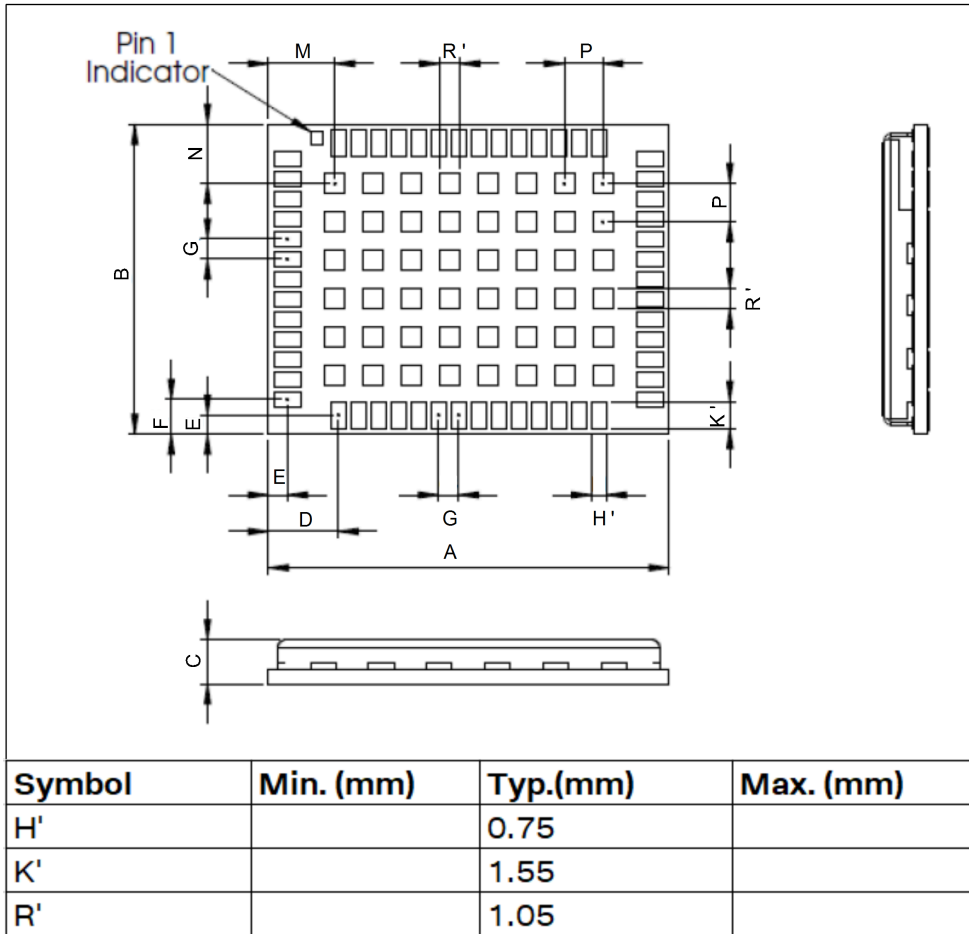

Figure 45: ZED-F9P suggested paste mask

4.7.3 Layout guidance

The presented layout guidance reduces the risk of performance issues at design level.

4.7.3.1 RF In trace

The RF in trace has to work in the combined GNSS L1 + L2 signal band.

For FR-4 PCB material with a dielectric permittivity of for example 4.7, the trace width for the 50 Ω line impedance can be calculated.

A grounded co-planar RF trace is recommended as it provides the maximum shielding from noise with adequate vias to the ground layer.

The RF trace must be shielded by vias to ground along the entire length of the trace and the ZED-F9P RF_IN pad should be surrounded by vias as shown in the figure below.

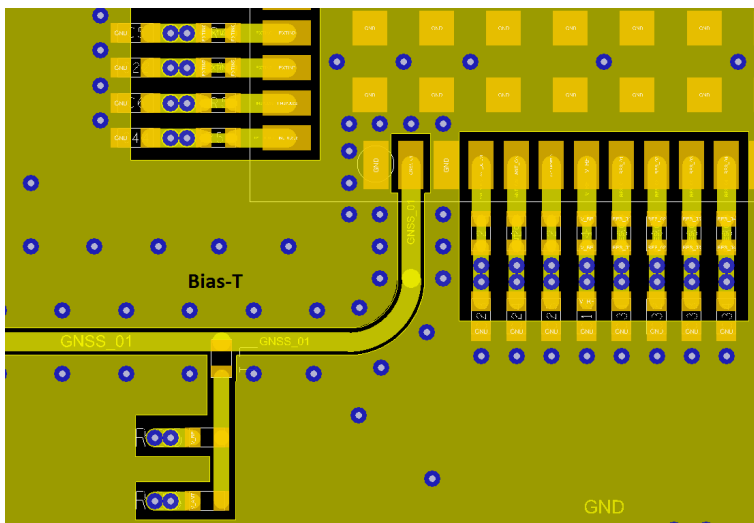

Figure 46: RF input trace

The RF_IN trace on the top layer should be referenced to a suitable ground layer.

4.7.3.2 Vias for the ground pads

The ground pads under the ZED-F9P high precision receiver need to be grounded with vias to the lower ground layer of the PCB. A solid ground layer fill on the top layer of the PCB is recommended. This is shown in the figure below.

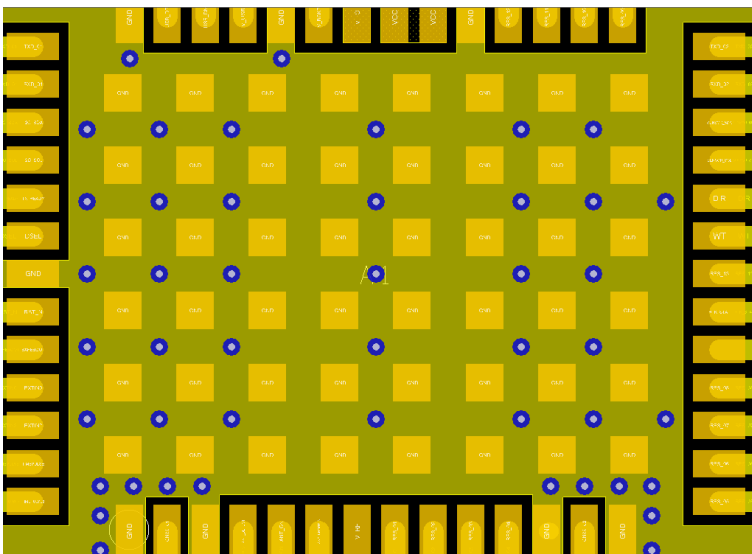

Figure 47: Top layer fill and vias

4.7.3.3 VCC pads

The VCC pads for the ZED-F9P high precision receiver must have as low impedance as possible with large vias to the lower power layer of the PCB. The VCC pads need a large combined pad and the decoupling capacitors must be placed as close as possible. This is shown in the figure below.

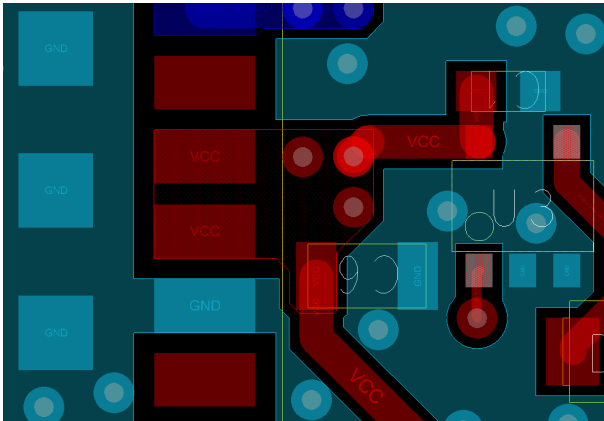

Figure 48: VCC pads

4.8 Design guidance

4.8.1 General considerations



Do not load Pin 4 (ANT_DETECT) with a capacitance more than 1 nF.

Check power supply requirements and schematic:

- Is the power supply voltage within the specified range and noise-free?
- If USB is not used, connect the V_USB pin to ground.
- It is recommended to have a separate LDO for V_USB that is enabled by the module VCC. This is to comply with the USB self-powered specification.
- If USB is used, is there a 1 uF capacitor right near the V_USB pin? This is just for the V_USB pin.
- Is there a 1 uF cap right next to the module VCC pin?
- Compare the peak current consumption of the ZED-F9P GNSS module with the specification of your power supply.
- GNSS receivers require a stable power supply. Avoid series resistance (less than 0.2 Ω) in your power supply line (the line to VCC) to minimize the voltage ripple on VCC. See the ZED-F9P [Power supply](#) section in the [Design](#) chapter for more information on the power supply requirements.
- Allow all I/O to Float/High impedance (High-Z) when VCC is not applied.

4.8.2 Backup battery

Check backup supply requirements and schematic:

- For achieving a minimal Time To First Fix (TTFF) after a power down (warm starts, hot starts), make sure to connect a backup battery to V_BCKP.
- Verify your battery backup supply can provide the battery backup current specified in the ZED-F9P datasheet.
- Allow all I/O including UART and other interfaces to Float/High impedance in HW backup mode (battery back-up connected with VCC removed).

4.8.3 RF front-end circuit options



It is important that the RF input is fed by an active antenna meeting the requirements for the ZED-F9P.

The first stages of the signal processing chain are crucial to the overall receiver performance.

When an RF input connector is employed this can provide a conduction path for harmful or destructive electrical signals. If this is a likely factor the RF input should be protected accordingly.

Additional points on the RF input

- What is the expected quality of the signal source (antenna)?
- What is the external active antenna signal power?
- What is the bandwidth and filtering of the external active antenna?
- Does the external antenna and filtering components meet the group delay variation requirements? This is critical for RTK.

Are destructive RF power levels expected to reach the RF input? Is interference from wireless transmitters expected?

- What are the characteristics of these signals (duty cycle, frequency range, power range, spectral purity)?
- What is the expected GNSS performance under interference conditions?

Is there a risk of RF input exposure to excessive ESD stress?

- In the field: Can the user access the connector?
- PCB / system assembly: Is there risk that statically charged parts (e.g. patch antennas) may be discharged through the RF input?

The following subsections provide several options addressing the various questions above:



In some applications, such as cellular transceivers, interference signals may exceed the maximum power rating of the RF_IN input. To avoid device destruction use of external input protection is mandatory.



During assembly of end-user devices which contain passive patch antennas, an ESD discharge may occur during production when pre-charged antennas are soldered to the GNSS receiver board. In such cases, use of external protection in front of RF_IN is mandatory to avoid device destruction.

ESD discharge cannot be avoided during assembly and / or field use. Note that SAW filters are susceptible to ESD damage. To provide additional robustness an ESD protection diode may be placed at the antenna RF connector to GND.

4.8.4 Antenna/RF input

Check RF input requirements and schematic:

- An OEM active antenna module that meets our requirements should be used if there is a need to integrate the antenna.
- The total maximum noise figure including external LNA (or the LNA in the active antenna) should be around 3 dB.
- Ensure active antenna gain is ideally between 30 - 40 dB gain.
- Make sure the antenna is not placed close to noisy parts of the circuitry and does not face any other noisy elements (for example micro-controller, display).
- Signal levels above 40 C/N0 average are required for optimal RTK performance.
- If a patch type antenna is used, a ground plane with minimum 100 - 150 mm diameter is required.
- Ensure antenna supports both L1 and L2 bands.
- Ensure antenna element gain is between 2 and 3 dBic typical for L1 and L2 bands.
- Ensure the group delay variation including active antenna is 10 ns max at each GNSS system bandwidth. Note: Inter-signal requirement 50 ns max.
- ESD protection on the RF input is mandatory.

- Bias-t inductor must be L1 and L2 band frequency selected with high impedance in the GNSS band.
- Ensure RF trace is tuned for 50 Ω to ensure L1 and L2 bandwidth.

4.8.5 Ground pads

Ensure the ground pads of the module are connected to ground.

4.8.6 Schematic design

For a **minimal design** with the ZED-F9P GNSS modules, consider the following functions and pins:

- Connect the power supply to VCC and V_BCKP.
- V_USB: If USB is used it is recommended V_USB is to be powered as per USB self-powered mode specification.
- If USB is not used connect V_USB to ground.
- Ensure an optimal ground connection to all ground pins of the ZED-F9P GNSS module.
- Choose the required serial communication interfaces (UART, USB, SPI or I2C) and connect the appropriate pins to your application.
- If you need hot or warm start in your application, connect a back-up battery to V_BCKP.
- Antenna bias is required, see ZED-F9P antenna bias section.

4.8.7 Layout design-in guideline

- Is the receiver placed away from heat sources?
- Is the receiver placed away from air-cooling sources?
- Is the receiver shielded by a cover/case to prevent the effects of air currents and rapid environmental temperature changes?
- Is the receiver placed as recommended in the [Layout](#) and [Layout guidance](#)?
- Assure a low serial resistance on the VCC power supply line (choose a line width > 400 μm).
- Keep the power supply line as short as possible.
- Add a ground plane underneath the module to reduce interference. This is especially important for the RF input line.
- For improved shielding, add as many vias as possible around the micro strip/co-planar waveguide, around the serial communication lines, underneath the module, etc.

5 Product handling

5.1 ESD handling precautions



ZED-F9P contains highly sensitive electronic circuitry and are Electrostatic Sensitive Devices (ESD). Observe precautions for handling! Failure to observe these precautions can result in severe damage to the GNSS receiver!

- Unless there is a galvanic coupling between the local GND (i.e. the work table) and the PCB GND, then the first point of contact when handling the PCB must always be between the local GND and PCB GND.
- Before mounting an antenna patch, connect ground of the device.
- When handling the RF pin, do not come into contact with any charged capacitors and be careful when contacting materials that can develop charges (e.g. patch antenna ~10 pF, coax cable ~50-80 pF/m or soldering iron).
- To prevent electrostatic discharge through the RF input, do not touch any exposed antenna area. If there is any risk that such exposed antenna area is touched in non-ESD protected work area, implement proper ESD protection measures in the design.
- When soldering RF connectors and patch antennas to the receiver's RF pin, make sure to use an ESD-safe soldering iron (tip)

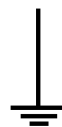

Connect first
to local GND

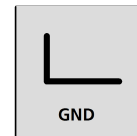

ESD Sensitive!

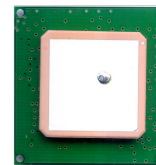
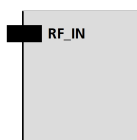

ESD safe only!



5.2 Soldering

Soldering paste

Use of “no clean” soldering paste is highly recommended, as it does not require cleaning after the soldering process has taken place. The paste listed in the example below meets these criteria.

- Soldering paste: OM338 SAC405 / Nr.143714 (Cookson Electronics)
- Alloy specification: Sn 95.5/ Ag 4/ Cu 0.5 (95.5% Tin/ 4% Silver/ 0.5% Copper)
- Melting temperature: 217 °C
- Stencil thickness: The exact geometry, distances, stencil thicknesses and solder paste volumes must be adapted to the specific production processes (e.g. soldering) of the customer.

Reflow soldering

A convection-type soldering oven is highly recommended over the infrared type radiation oven. Convection-heated ovens allow precise control of the temperature, and all parts will heat up evenly, regardless of material properties, thickness of components and surface color.

As a reference, see the “IPC-7530 Guidelines for temperature profiling for mass soldering (reflow and wave) processes”, published in 2001.

Preheat phase

During the initial heating of component leads and balls, residual humidity will be dried out. Note that this preheat phase will not replace prior baking procedures.

- Temperature rise rate: max. 3 °C/s. If the temperature rise is too rapid in the preheat phase it may cause excessive slumping
- Time: 60 – 120 s. If the preheat is insufficient, rather large solder balls tend to be generated. Conversely, if performed excessively, fine balls and large balls will be generated in clusters
- End temperature: 150 – 200 °C. If the temperature is too low, non-melting tends to be caused in areas containing large heat capacity

Heating - reflow phase

The temperature rises above the liquidus temperature of 217°C. Avoid a sudden rise in temperature as the slump of the paste could become worse.

- Limit time above 217 °C liquidus temperature: 40 – 60 s
- Peak reflow temperature: 245 °C

Cooling phase

A controlled cooling prevents negative metallurgical effects (solder becomes more brittle) of the solder and possible mechanical tensions in the products. Controlled cooling helps to achieve bright solder fillets with a good shape and low contact angle.

- Temperature fall rate: max 4 °C/s



To avoid falling off, the modules should be placed on the topside of the motherboard during soldering.

The final soldering temperature chosen at the factory depends on additional external factors such as the choice of soldering paste, size, thickness and properties of the base board, etc. Exceeding the maximum soldering temperature in the recommended soldering profile may permanently damage the module.

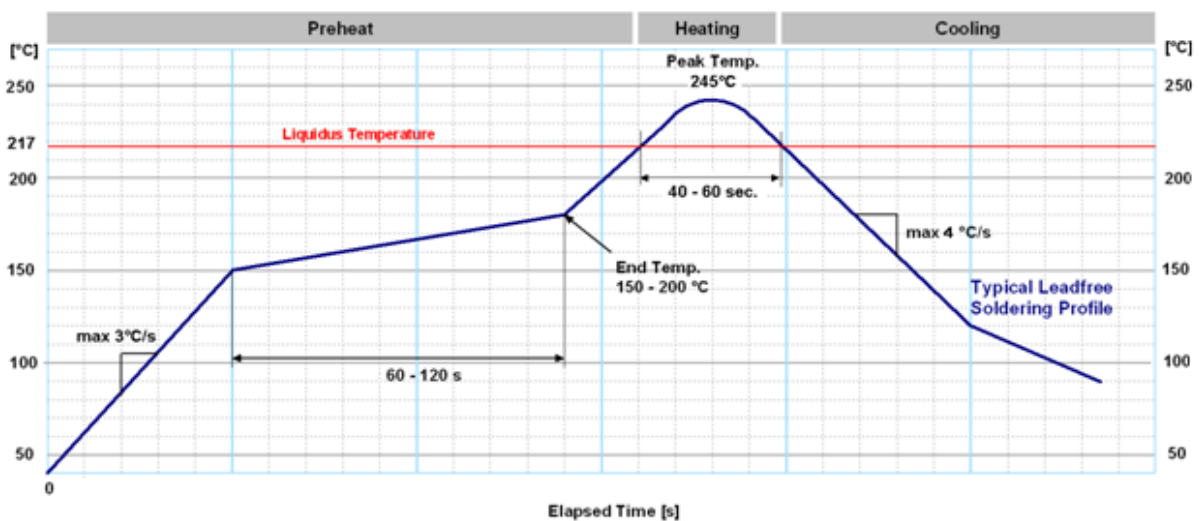



Figure 49: Soldering Profile

 Modules **must not** be soldered with a damp heat process.

Optical inspection

After soldering the module, consider an optical inspection step.

Cleaning

 No cleaning with water, solvent, ultrasonic cleaner should be carried out:

- Cleaning with water will lead to capillary effects where water is absorbed in the gap between the baseboard and the module. The combination of residues of soldering flux and encapsulated water leads to short circuits or resistor-like interconnections between neighboring pads.
- Cleaning with alcohol or other organic solvents can result in soldering flux residues flooding into the two housings, areas that are not accessible for post-wash inspections. The solvent will also damage the sticker and the ink-jet printed text.
- Ultrasonic cleaning will permanently damage the module, in particular the quartz oscillators.

The best approach is to use a "no clean" soldering paste and eliminate the cleaning step after the soldering.

Repeated reflow soldering

Only single reflow soldering processes are recommended for boards populated with modules. Modules should not be submitted to two reflow cycles on a board populated with components on both sides in order to avoid upside down orientation during the second reflow cycle. In this case, the module should always be placed on that side of the board, which is submitted into the last reflow cycle. The reason for this (besides others) is the risk of the module falling off due to the significantly higher weight in relation to other components.

Two reflow cycles can be considered by excluding the above described upside down scenario and taking into account the rework conditions described in this section.

 Repeated reflow soldering processes and soldering the module upside down are not recommended.

Wave soldering

Base boards with combined through-hole technology (THT) components and surface-mount technology (SMT) devices require wave soldering to solder the THT components. Only a single wave soldering process is encouraged for boards populated with modules.

Rework

We do not recommend using a hot air gun because this is an uncontrolled process and might damage the module.

 Use of a hot air gun can lead to overheating and severely damage the module. Always avoid overheating the module.

After the module is removed, clean the pads before re-applying solder paste, placing and reflow soldering a new module.

 Never attempt a rework on the module itself, e.g. replacing individual components. Such actions immediately terminate the warranty.

Conformal coating

Certain applications employ a conformal coating of the PCB using HumiSeal® or other related coating products. These materials affect the RF properties of the GNSS module and it is important

to prevent them from flowing into the module. The RF shields do not provide 100% protection for the module from coating liquids with low viscosity; therefore, care is required in applying the coating.

Conformal coating of the module will void the warranty.

Casting

If casting is required, use viscose or another type of silicon pottant. The OEM is strongly advised to qualify such processes in combination with the module before implementing this in the production.

Casting will void the warranty.

Grounding metal covers

Attempts to improve grounding by soldering ground cables, wick or other forms of metal strips directly onto the EMI covers is done at the customer's own risk. The numerous ground pins should be sufficient to provide optimum immunity to interferences and noise.

u-blox makes no warranty for damages to the module caused by soldering metal cables or any other forms of metal strips directly onto the EMI covers.

Use of ultrasonic processes

Some components on the module are sensitive to ultrasonic waves. Use of any ultrasonic processes (cleaning, welding etc.) may cause damage to the GNSS receiver.

u-blox offers no warranty against damages to the module caused by any ultrasonic processes.

5.3 Tapes

Figure 50 shows the feed direction and illustrates the orientation of the ZED-F9P on the tape:

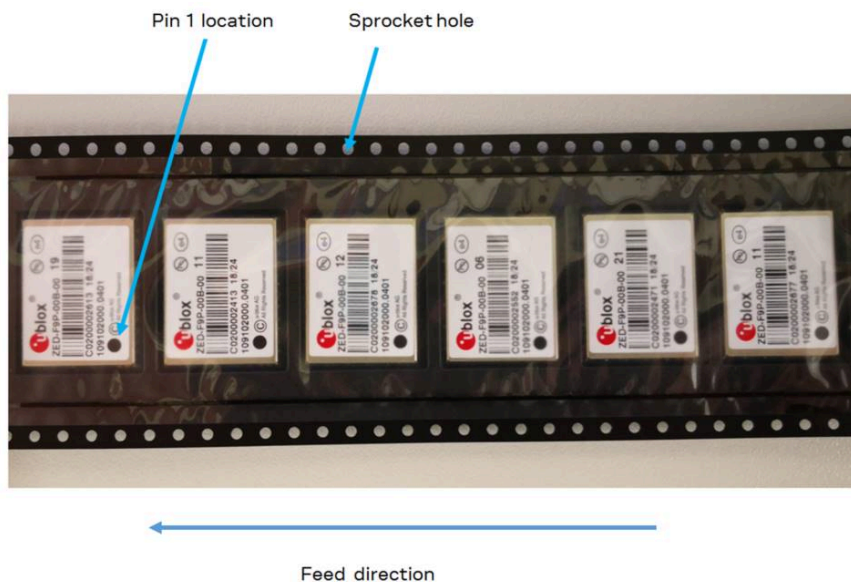

Figure 50: Orientation of ZED-F9P on the tape

The feed direction to the pick and place pick-up is shown by the orientation of the ZED pin 1 location. In Figure 50, with pin 1 location on the bottom of the tape, the feed direction into the pick and place pick-up is from the reel (located on the right of the figure) towards left.

The dimensions of the tapes for ZED-F9P are specified in Figure 51 (measurements in mm).

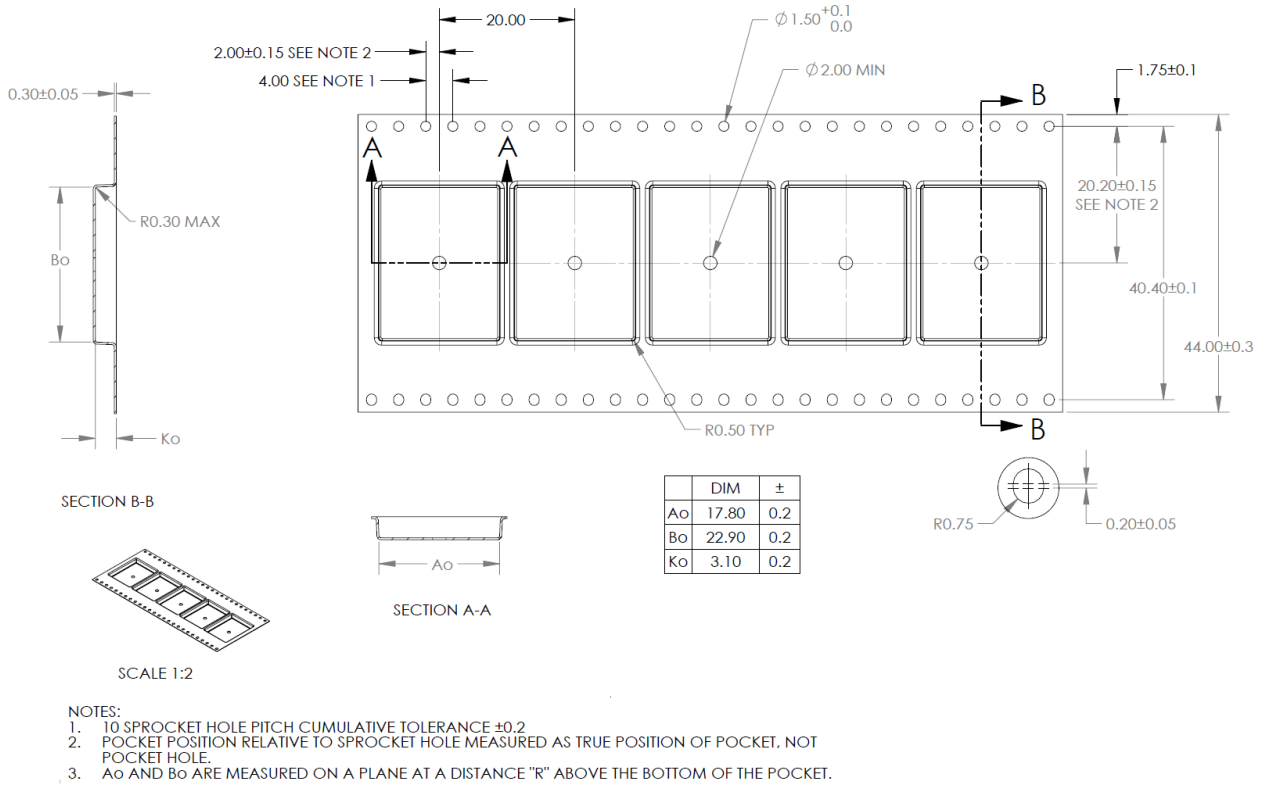

Figure 51: ZED-F9P tape dimensions (mm)

5.4 Reels

The ZED-F9P high precision receiver GNSS modules are deliverable in quantities of 250 pieces on a reel. The ZED-F9P high precision receiver receivers are shipped on Reel Type B, as specified in the u-blox Package Information Guide. See the u-blox Package Information Guide [3].

5.5 Moisture sensitivity levels

The moisture sensitivity level (MSL) for ZED-F9P is specified in the table below.

Package	MSL level
LGA	4

Table 32: MSL level



For MSL standard see IPC/JEDEC J-STD-020, which can be downloaded from www.jedec.org.



For more information regarding moisture sensitivity levels, labeling, storage and drying, see the u-blox Package Information Guide [3].

Appendix

A Glossary

Abbreviation	Definition
ANSI	American National Standards Institute
ARP	Antenna Reference Point
BeiDou	Chinese navigation satellite system
BBR	Battery-backed RAM
CDMA	Code Division Multiple Access
EMC	Electromagnetic Compatibility
EMI	Electromagnetic Interference
EOS	Electrical Overstress
EPA	Electrostatic Protective Area
ESD	Electrostatic Discharge
Galileo	European navigation satellite system
GLONASS	Russian navigation satellite system
GND	Ground
GNSS	Global navigation satellite system
GPS	Global Positioning System
GSM	Global system for mobile communications
I2C	Inter-integrated circuit bus
IEC	International Electrotechnical Commission
ITRF	International Terrestrial Reference Frame
MB	Moving base
MSM	Multiple Signal Messages
NTRIP	Networked transport of RTCM via internet protocol
PCB	Printed Circuit Board
QZSS	Quasi-Zenith Satellite System
RF	Radio frequency
RTCM	Radio Technical Commission for Maritime
RTK	Real Time Kinematic
SBAS	Satellite-based Augmentation System
SV	Space Vehicle, a satellite
TDOP	Time Dilution Of Precision
UBX	u-blox
QZSS	Quasi-Zenith Satellite System

B RTCM ITRF geodetic models

Real time kinematic (RTK) is a differential system where the rover uses the reference datum of the reference station. The International Terrestrial Reference Frame (ITRF) must be obtained from the reference network and then used to transform the rover position output to match the required reference frame. The rover does not output the position in the local receiver WGS84 (based on ITRF2008) datum, it matches the reference receiver (or base) reference frame. The user application

needs to do the transformation for use in a mapping application if it does not use the same reference frame. An offset can occur if this is not done.

The ITRF reference frame years are listed below:

- ITRF94
- ITRF96
- ITRF97
- ITRF2000
- ITRF2005
- ITRF2008
- ITRF2014

There are other similar reference systems used by GNSS correction services, such as the ETRS89.

For example, the EUREF network uses the ETRS89 reference frame. For information, see their homepage: [EUREF](#).

See the ITRF website for more information and an online transform calculator: [ITRF](#).

Another online tool is available on the EUREF network page: [Transformation](#).

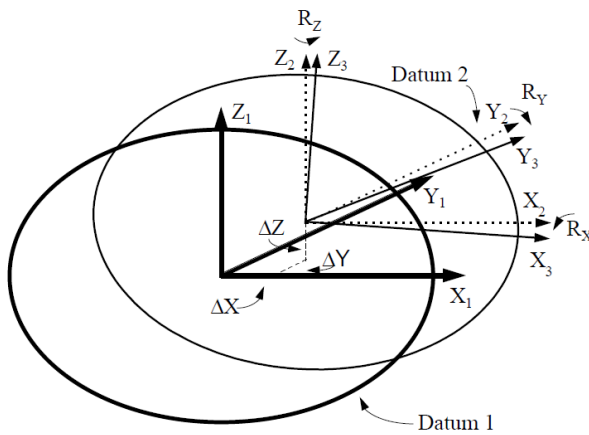

Figure 52: Transforming between two datums

The user needs to transform the frame of the reference receiver (or base) into the required system being used by their application and mapping system. If comparing the rover position with a reference system, the same RTCM stream should be used to ensure that the reference and the rover output the same position. If the reference system is post-processed, its output must be transformed to the same ITRF and datum being used by the rover.

For example, when viewing RTK-accurate positions that could be in any ITRF transform reference frame (based on reference receiver (or base) reference frame) on Google Earth: The heights on Google Earth refer to EGM96 and are, therefore, Geoidal heights.

The lat/long are referred to the WGS 84 (ITRF2008) ellipsoid. The result is a visible inaccuracy, and the RTK receivers' position output must be transformed to the Google Earth transform system before it can be used. This ignores any local map tile inaccuracies.

Geodetic coordinate systems and ellipsoids

In practice, the relevant organizations choose to keep their respective frames very close to the International Terrestrial Reference Frame (ITRF), defined and managed by the International Earth Rotation and Reference Systems Service (IERS).

However, because the Earth's tectonic plates and even parts of the Earth's core move, new versions of ITRF are defined every few years, generally with changes of the order of a few millimeters. Consequently, the major GNSS occasionally decide that they need to update their reference frames to be better aligned with the latest ITRF.

So, for example, GPS switched to WGS84 (G1150) in GPS week 1150 (early 2002) based on ITRF2000, while GLONASS switched from PZ90.02 to PZ90.11 at the end of 2013, based on ITRF2008. The net effect of this is that all the major GNSS use almost the same reference frames, but there are some small (generally sub-centimeter) differences between them, and these differences occasionally change.

In order to produce positions that can be shown on a map, it is necessary to translate between raw coordinates (for example, x, y, z) and a position relative to the Earth's surface (for example, latitude, longitude and altitude), and that requires defining the form of ellipsoid that best matches the shape of the Earth.

Historically, many different ellipsoid definitions have been used for maps, many of which predate the existence of GNSS and show quite significant differences, leading to discrepancies of as much as 100 meters in places. Fortunately, most digital maps now use the WGS84 ellipsoid, which is distinct from the WGS84 coordinate system, but defined by the same body.

However, for RTK position accuracies now in the centimeter-level, the ITRF year for the WGS84 datum used by the mapping system must be known in order to transform the RTK rover position into the correct reference frame.



The ZED-F9P stores the EGM96 geoid model with limited resolution, leading to degraded accuracy of the reported mean sea level height and geoid separation. If the user application needs higher geoid separation accuracy, it is required to apply its own adjustment to the ellipsoidal height output from the ZED-F9P.

C RTK configuration procedures with u-center

This section provides some guidance when using u-center to configure base and rover operation.

C.1 Base configuration with u-center

This section describes setting a static base configuration in the u-center "Messages View" window.

Start u-center and connect to the ZED-F9P device. Under the UBX-CFG message tree, three configuration messages are listed:

- **CFG-VALDEL**: Allows configuration deletion
- **CFG-VALGET**: Allows configuration reading
- **CFG-VALSET**: Allows configuration setting

All configuration item setting is done using the **UBX-CFG-VALSET** dialog. The general operation is as follows:

1. To open a configuration setting dialog, select **UBX-CFG-VALSET** in the message tree list.
2. Select the required **Group** in the "Compose list entry" section.
3. Select the associated key in the "Key name" pull-down menu.
4. Once you have selected the configuration key, move it to the configuration changes list by clicking **Add to List**.

You can edit or read key values from the receiver after selecting items in the "Configuration changes to send" list. See [Figure 53](#) below.

Figure 53: u-center UBX-CFG-VALSET message view

Use the following procedure to configure the module for base station operation:

Setting the required RTCM message output can be done in one session.

1. Select **Group:** CFG-MSGOUT, **Key name:** CFG-MSGOUT-RTCM3X, and select the UART1 required messages.
2. Add each message to the list and set the value of each to 1.
3. Click **Send**

See [Figure 54](#) below.

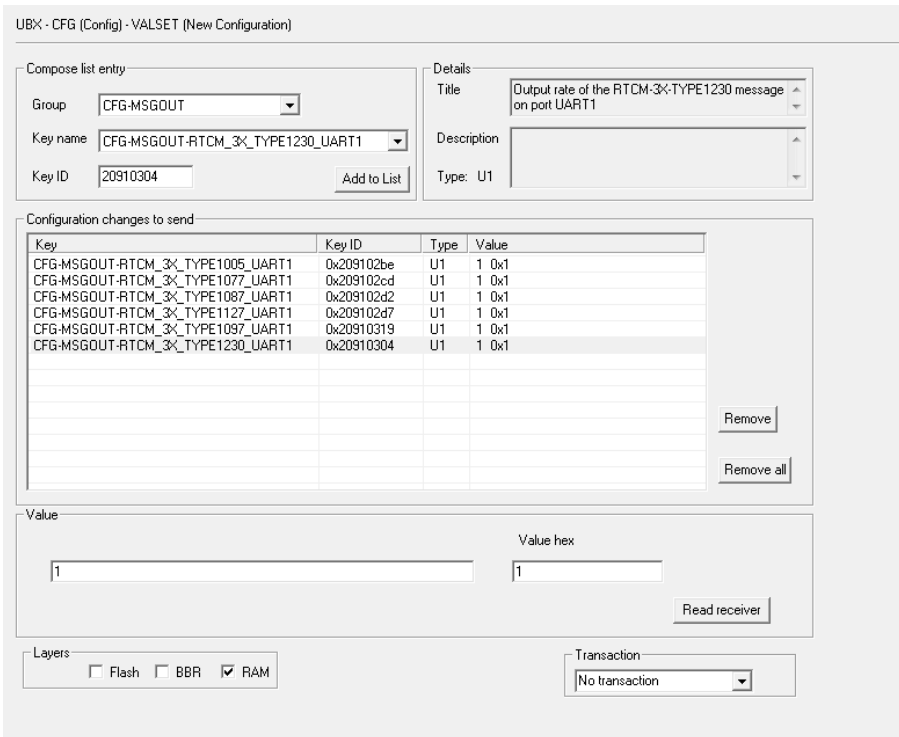

Figure 54: Base station: u-center UBX-CFG-VALSET message view for setting the CFG-MSGGOUT-* configuration group for enabling the output of the required RTCM messages

The configuration illustration shows the use of RTCM MSM7 messages. MSM4 messages are equally applicable as recommended in the receiver configuration section.

Set the receiver into base mode by enabling a survey-in procedure or specify fixed coordinates via items within the CFG-TMODE configuration group. An example of survey-in configuration is shown below.

UBX - CFG (Config) - VALSET (New Configuration)

Compose list entry

Group:

Key name:

Key ID:

Details

Title:

Description:

Type: U4

Configuration changes to send

Key	Key ID	Type	Value
CFG-TMODE-MODE	0x20030001	E1	1 - SURVEY_IN
CFG-TMODE-SVIN_ACC_LIMIT	0x40030011	U4	50000 0xc350 mm scaled 0.1
CFG-TMODE-SVIN_MIN_DUR	0x40030010	U4	60 0x3c s

Value

unit: s

Layers: Flash BBR RAM

Transaction:

Figure 55: Base station: u-center UBX-CFG-VALSET message view for setting the CFG-TMODE-* configuration group required for performing a survey-in

When using the survey-in mode, you must select reasonable settings based on the environment and achievable accuracy in the base location. A figure of 50000 (0.1 mm x 50000 = 5 m) for estimated accuracy and survey-in time of 60 seconds is a sensible starting point. In good satellite visibility, the base is unlikely to achieve an accuracy better than 1 m.

In multi-path conditions, the time to achieve a specified accuracy can take longer than expected. You may need to relocate the base antenna or extend the required accuracy and/or survey-in time. You can monitor the status of the survey-in status using the NAV-SVIN message.

The receiver will output messages upon configuration setting, however RTCM 1005 will **only** be output once the survey-in is completed, or the fixed coordinates are entered for the base antenna. Use the u-center "Packet Console View" to verify message output. Once surveyed in correctly, it will indicate a TIME solution mode in the u-center Data view. See below in [Figure 56](#).

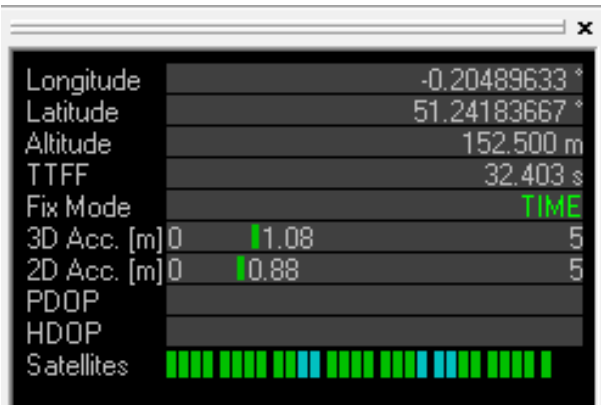

Figure 56: Base station: u-center data view in TIME mode

C.2 Rover configuration with u-center

This overview will help when setting up a rover when using u-center.

In this procedure, the UART1 is set with an appropriate baud rate for communicating with a host. Then a set of output messages are set to enable receiver status monitoring.

Using the **UBX-CFG-VALSET** configuration window in the u-center **Message View**, set the UART1 interface for the correct host baud rate:

1. Select **Group:** CFG-UART1, **Key name:** CFG-UART1-BAUDRATE. See [Figure 57](#).

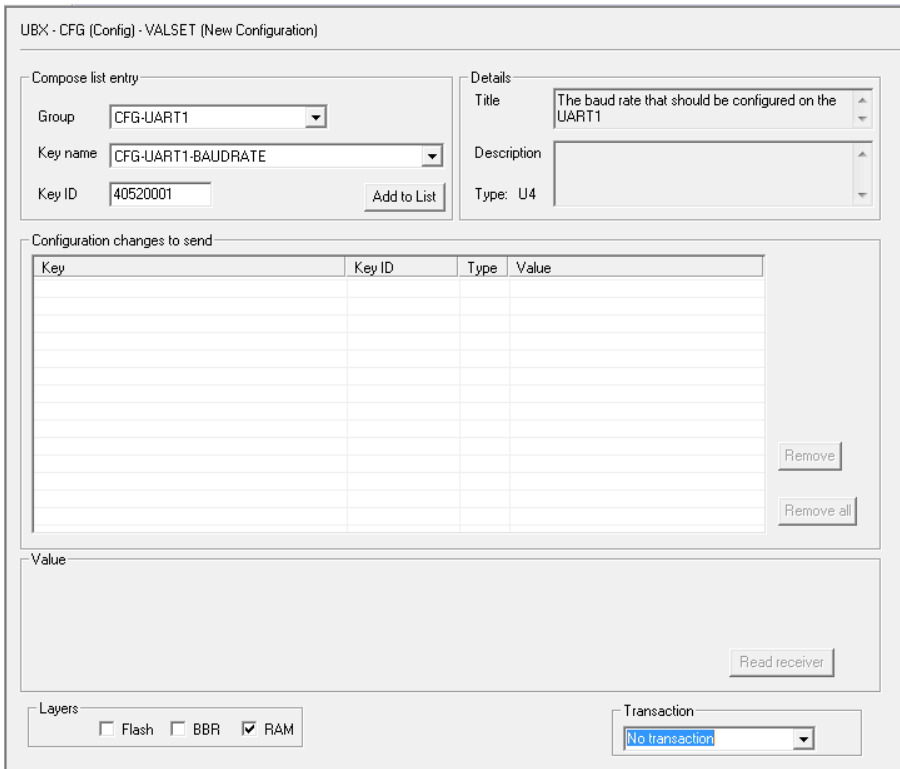

Figure 57: u-center UBX-CFG-VALSET message view

2. Select **Add to List**, it will appear in the table below.

3. Select the added **Key**. It will now give the option of setting or reading the current value. See [Figure 58](#).

Figure 58: Example u-center UBX-CFG-VALSET message view when selecting a configuration item

4. Next add the value, for example, 230400, into the **Value** window that appears below the list. See [Figure 59](#).

- Then set the configuration by clicking the **Send** button at the bottom of the message tree view. Remember to set the u-center baud rate to match the value set in the receiver.

UBX - CFG (Config) - VALSET (New Configuration)

Compose list entry:

Group:

Key name:

Key ID:

Details:

Title:

Description:

Type: U4

Configuration changes to send:

Key	Key ID	Type	Value
CFG-UART1-BAUDRATE	0x40520001	U4	230400 0x38400

Value: Value hex:

Layers: Flash BBR RAM

Transaction:

Figure 59: Rover: u-center UBX-CFG-VALSET message view for setting the CFG-UART1-BAUDRATE configuration item that controls the baudrate of UART1

Next, some UBX example messages are configured to enable viewing the rover status.

- Select **Group** CFG-MSGOUT, **Key name:** CFG-MSGOUT-UBX and select the UART1 required messages.
- Add each message to the list, setting the value of each to 1.

3. Click **Send**. See [Figure 60](#).

UBX - CFG (Config) - VALSET (New Configuration)

Compose list entry

Group:

Key name:

Key ID:

Details

Title:

Description:

Type: U1

Configuration changes to send

Key	Key ID	Type	Value
CFG-MSGOUT-UBX_NAV_SIG_UART1	0x20910346	U1	-
CFG-MSGOUT-UBX_NAV_PVT_UART1	0x20910007	U1	-
CFG-MSGOUT-UBX_NAV_POSLLH_UART1	0x2091002a	U1	-
CFG-MSGOUT-UBX_NAV_RELPOSNED_UART1	0x2091008e	U1	-
CFG-MSGOUT-UBX_NAV_STATUS_UART1	0x2091001b	U1	-

Value

Layers: Flash BBR RAM

Transaction:

Figure 60: Rover: u-center UBX-CFG-VALSET message view for setting the CFG-MSGOUT-* configuration items for enabling the output of some recommended UBX messages

To ensure all the required RTCM messages, including most importantly RTCM 1005 or 4072.0, are being received regularly, examine the **UBX-RXM-RTCM** output in u-center. See [Figure 61](#).

UBX - RXM (Receiver Manager) - RTCM (RTCM input status)

Statistics:

Message Type	Total messages	CRC passed messages	CRC failed messages	(Last) Reference Station ID
0	0	0	0	n/a
1002	0	0	0	n/a
1005	33	33	0	0
1009	0	0	0	n/a
1010	0	0	0	n/a
1074	0	0	0	n/a
1077	33	33	0	0
1084	0	0	0	n/a
1087	33	33	0	0
1097	33	33	0	0
1124	0	0	0	n/a
1127	33	33	0	0
1230	33	33	0	0
1001	0	0	0	n/a

* Messages not supported by the receiver

Current messages:

ix	Reference Station ID	Message ID	CRC check
198	0	1005	Passed
197	0	1230	Passed
196	0	1127	Passed
195	0	1097	Passed
194	0	1087	Passed
193	0	1077	Passed
192	0	1005	Passed
191	0	1230	Passed
190	0	1127	Passed
189	0	1097	Passed
188	0	1087	Passed
187	0	1077	Passed
186	0	1005	Passed
185	0	1230	Passed
184	0	1127	Passed

Figure 61: Rover: u-center UBX-RXM-RTCM view

Once the rover has started to receive valid RTCM messages, it will transition through 3D Fix to 3D/DGNSS to Float, and, ultimately, into Fixed mode. This will occur when it is receiving all required RTCM messages, including RTCM 1005 or 4072.0, under sufficient signal conditions. See [Figure 62](#).

Longitude	-0.20488940 °
Latitude	51.24184640 °
Altitude	151.161 m
TTFF	15.137 s
Fix Mode	3D/DGNSS/FIXED
3D Acc. [m]	0.02
2D Acc. [m]	0.01
PDOP	1.2
HDOP	5
Satellites	12

Figure 62: Rover: u-center data view with RTK Fixed



If using a virtual reference service, the rover must output the NMEA GGA message to return to the NTRIP caster. Without this, the NTRIP caster will not provide correction information. NMEA messages are enabled by default on the UART1, I2C, SPI and USB interface.

D Stacked patch antenna

A typical low-cost L1 + L2 antenna is based on a stacked patch antenna design. This consists of two discrete ceramic patch elements with an L1 patch above an L2 patch.

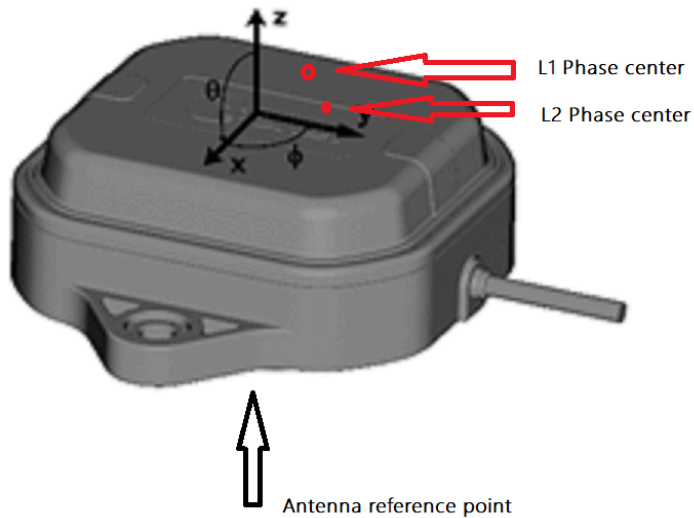

Figure 63: Stacked patch antenna

The absolute antenna position for a survey-grade antenna is normally given as the antenna reference point (ARP), usually specified at a mechanical mounting point. The antenna nominal phase center is given by a phase center combination of the L1 and L2 patches. Survey-grade antenna makers provide offset data for phase variation with respect to the ARP.

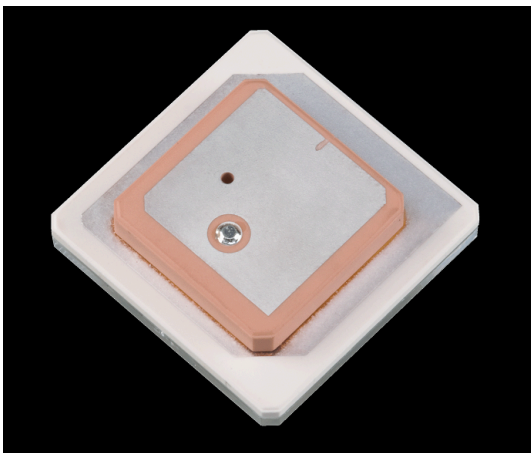

Figure 64: Ceramic stack

When used in an application, the antenna placement affects the phase center variation owing to the size and shape of the ground plane coupled with the effects of the adjacent structures. A phase center variation calibration is required to check the average phase center. A successful calibration can be made if the phase variation of a specific antenna is repeatable between samples.

To obtain the best antenna performance in an automotive application, mount the antenna in the center of a conductive car roof without any inclination. The antenna requires good signal levels and as wide a view of the sky as possible. The antenna must not be placed under a dashboard, in the rear view mirror, or on the rear parcel shelf.

An L1 + L2 stacked patch antenna must have a good band-pass performance from the patch elements with low attenuation from SAW band-pass filtering. An example of the measured frequency characteristics of a low-cost L1 + L2 antenna is shown below.

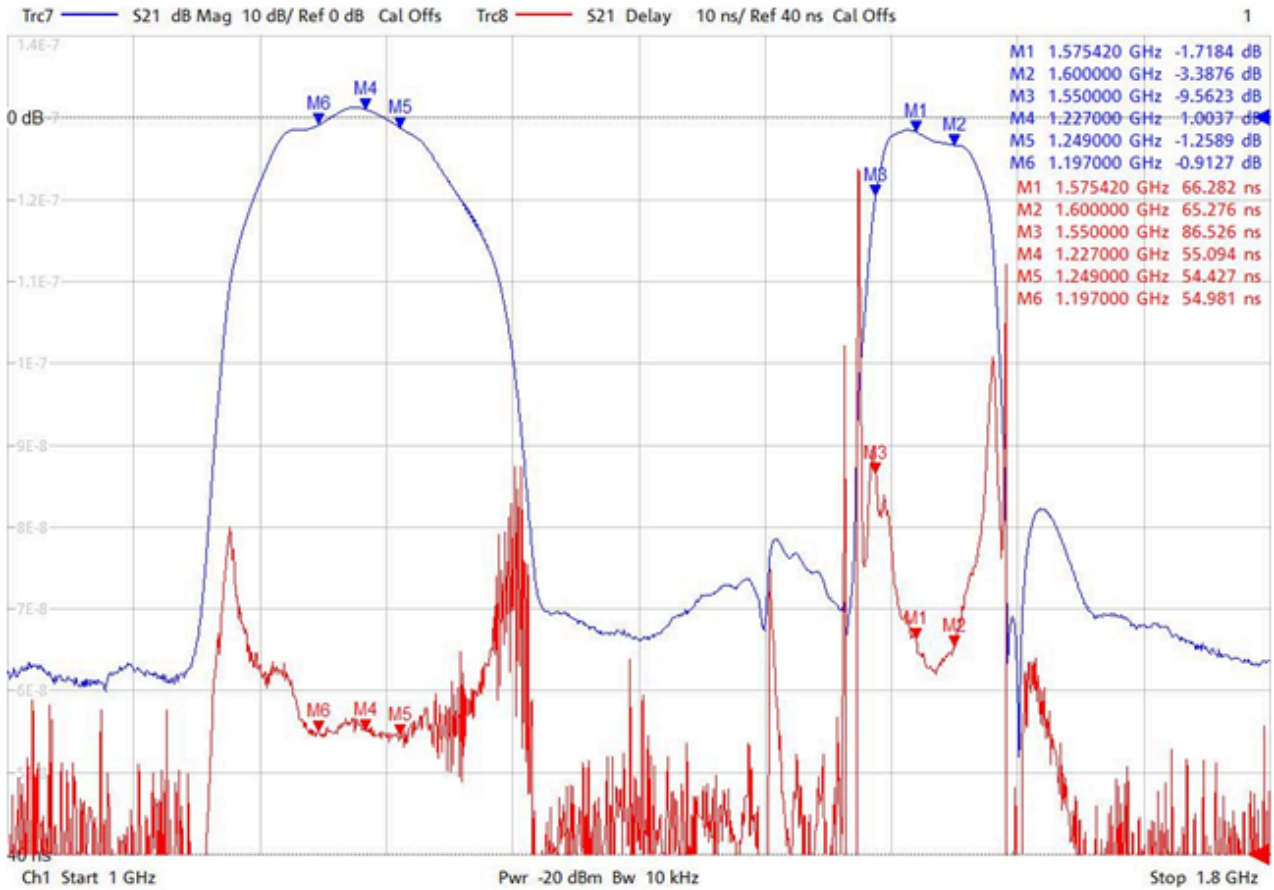

Figure 65: Low-cost L1/L2 antenna band characteristics

The u-blox low-cost antenna design is shown below, followed by some examples of antennas from other manufacturers which can be used with ZED-F9P.

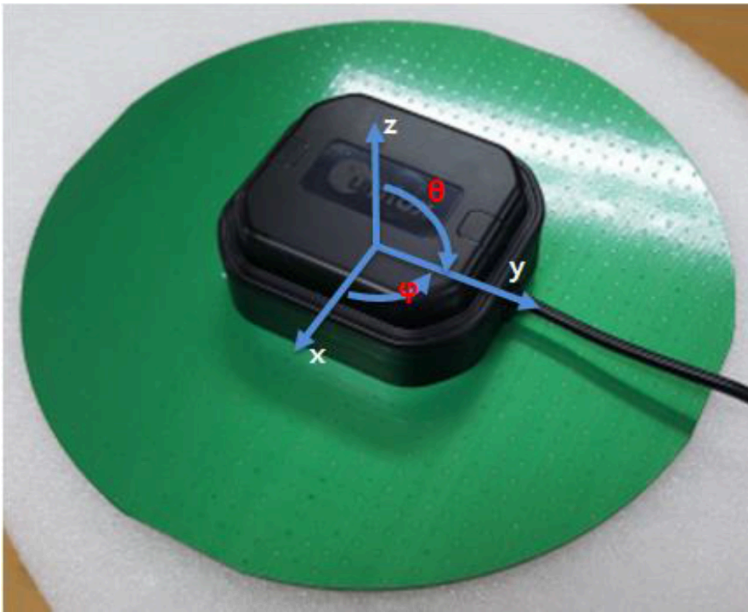

Figure 66: u-blox low-cost L1/L2 RTK antenna

There are antenna types that can be used without a substantial ground plane, such as a helical antenna type. This is a useful solution where space is limited, for example, for drone or small form factor applications.

Related documents

- [1] ZED-F9P Data sheet, doc. no. UBX-17051259
- [2] ZED-F9P Interface description, doc. no. UBX-18010854
- [3] u-blox Package Information Guide, doc. no. UBX-14001652
- [4] ZED-F9P Moving Base application note, doc. no. UBX-19009093



For regular updates to u-blox documentation and to receive product change notifications please register on our homepage (<http://www.u-blox.com>).

Revision history

Revision	Date	Name	Status / comments
R01	22-May-2018	ghun	Objective specification
R02	03-Oct-2018	ghun	Advance information
R03	20-Dec-2018	byou	HPG 1.10 advance information
R04	1-Mar-2019	byou	HPG 1.11 early production information. Added a design-in restriction for ANT_DETECT pin in section Design.
R05	22-Aug-2019	ghun	HPG 1.12 Early Production Information.
R06	15-Jan-2020	dama	Tape feed and dimension pictures updated. PCN UBX-19057484 added and module type number updated.
R07	25-Feb-2020	jhak	Updated minimum and maximum gains in Antenna specifications table.
R08	02-Jun-2020	dama	HPG 1.13 update. ZED-F9P-02B-00 update.

Contact

For complete contact information visit us at www.u-blox.com.

u-blox Offices

North, Central and South America

u-blox America, Inc.

Phone: +1 703 483 3180
E-mail: info_us@u-blox.com

Regional Office West Coast

Phone: +1 408 573 3640
E-mail: info_us@u-blox.com

Technical Support

Phone: +1 703 483 3185
E-mail: support_us@u-blox.com

Headquarters

Europe, Middle East, Africa

u-blox AG

Phone: +41 44 722 74 44
E-mail: info@u-blox.com
Support: support@u-blox.com

Asia, Australia, Pacific

u-blox Singapore Pte. Ltd.

Phone: +65 6734 3811
E-mail: info_ap@u-blox.com
Support: support_ap@u-blox.com

Regional Office Australia

Phone: +61 2 8448 2016
E-mail: info_anz@u-blox.com
Support: support_ap@u-blox.com

Regional Office China (Beijing)

Phone: +86 10 68 133 545
E-mail: info_cn@u-blox.com
Support: support_cn@u-blox.com

Regional Office China (Chongqing)

Phone: +86 23 6815 1588
E-mail: info_cn@u-blox.com
Support: support_cn@u-blox.com

Regional Office China (Shanghai)

Phone: +86 21 6090 4832
E-mail: info_cn@u-blox.com
Support: support_cn@u-blox.com

Regional Office China (Shenzhen)

Phone: +86 755 8627 1083
E-mail: info_cn@u-blox.com
Support: support_cn@u-blox.com

Regional Office India

Phone: +91 80 4050 9200
E-mail: info_in@u-blox.com
Support: support_in@u-blox.com

Regional Office Japan (Osaka)

Phone: +81 6 6941 3660
E-mail: info_jp@u-blox.com
Support: support_jp@u-blox.com

Regional Office Japan (Tokyo)

Phone: +81 3 5775 3850
E-mail: info_jp@u-blox.com
Support: support_jp@u-blox.com

Regional Office Korea

Phone: +82 2 542 0861
E-mail: info_kr@u-blox.com
Support: support_kr@u-blox.com

Regional Office Taiwan

Phone: +886 2 2657 1090
E-mail: info_tw@u-blox.com
Support: support_tw@u-blox.com